

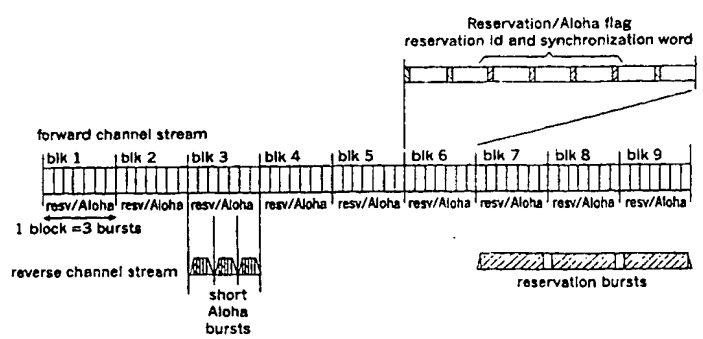

INTERNATIONAL APPLICATION PUBLISHED UNDER THE PATENT COOPERATION TREATY (PCT)

<p>(51) International Patent Classification ⁶ : H04L 12/56</p>	<p>A1</p>	<p>(11) International Publication Number: WO 98/37669 (43) International Publication Date: 27 August 1998 (27.08.98)</p>
<p>(21) International Application Number: PCT/SE98/00326 (22) International Filing Date: 24 February 1998 (24.02.98) (30) Priority Data: 08/806,082 25 February 1997 (25.02.97) US (71) Applicant: TELEFONAKTIEBOLAGET LM ERICSSON (publ) [SE/SE]; S-126 25 Stockholm (SE). (72) Inventors: WRIGHT, Andrew, S.; Suite 310, 1432 West 10th Avenue, Vancouver, British Columbia V6H 1J9 (CA). LAI, Cuong, H.; 4-3405 E. 49th Avenue, Vancouver, British Columbia V5S 1M1 (CA). SHIN, Soon, S.; Suite 307, 343 East 8th Avenue, Vancouver, British Columbia V5T 1S1 (CA). NEWTON, Helen, R.; Suite 310, 1432 West 10th Avenue, Vancouver, British Columbia V6H 1J9 (CA). (74) Agent: ERICSSON RADIO SYSTEMS AB; Common Patent Dept., S-164 80 Stockholm (SE).</p>		<p>(81) Designated States: AL, AM, AT, AU, AZ, BA, BB, BG, BR, BY, CA, CH, CN, CU, CZ, DE, DK, EE, ES, FI, GB, GE, GH, GM, GW, HU, ID, IL, IS, JP, KE, KG, KP, KR, KZ, LC, LK, LR, LS, LT, LU, LV, MD, MG, MK, MN, MW, MX, NO, NZ, PL, PT, RO, RU, SD, SE, SG, SI, SK, SL, TJ, TM, TR, TT, UA, UG, UZ, VN, YU, ZW. ARIPO patent (GH, GM, KE, LS, MW, SD, SZ, UG, ZW), Eurasian patent (AM, AZ, BY, KG, KZ, MD, RU, TJ, TM), European patent (AT, BE, CH, DE, DK, ES, FI, FR, GB, GR, IE, IT, LU, MC, NL, PT, SE), OAPI patent (BF, BJ, CF, CG, CI, CM, GA, GN, ML, MR, NE, SN, TD, TG).</p> <p>Published <i>With international search report. Before the expiration of the time limit for amending the claims and to be republished in the event of the receipt of amendments.</i></p>

(54) Title: MULTIPLE ACCESS COMMUNICATION NETWORK WITH COMBINED CONTENTION AND RESERVATION MODE ACCESS



(57) Abstract

Channel access for communicating a data packet over a multiple access communication network with a forward channel and a multiple access reverse channel which efficiently handles a mix of short message and long data transfer communication type traffic is provided by combined contention and reservation mode access to the multiple reverse channel. A forward channel transmission apparatus or base station broadcasts a forward channel control packet associated with a subsequent transmission window which channel control packet includes an indication of contention or reservation mode for the subsequent transmission window and an identifier identifying a device to be granted reservation mode access to the reverse channel. The forward channel transmission apparatus allocates access to reservation mode transmissions responsive to reservation requests transmitted by reverse channel transmission apparatus or subscriber devices having data packets to transmit which exceed the data packet size which may be transmitted within the constraints of a contention mode burst. For short length data packets, the reverse channel transmission apparatus transmits the data packet in a contention window rather than transmitting a reservation request to obtain reservation mode access to the reverse channel for transmission of the data packet. The base station further transmits an acknowledgment of successfully received data packets allowing the subscriber device to submit for retransmission data packets which are not successfully transmitted without the need to involve higher layer error recovery mechanisms. The broadcast channel control packet is associated with a subsequent transmission window so that the reverse channel transmission apparatus may be provided with slow receive to transmit switching time hardware.

FOR THE PURPOSES OF INFORMATION ONLY

Codes used to identify States party to the PCT on the front pages of pamphlets publishing international applications under the PCT.

AL	Albania	ES	Spain	LS	Lesotho	SI	Slovenia
AM	Armenia	FI	Finland	LT	Lithuania	SK	Slovakia
AT	Austria	FR	France	LU	Luxembourg	SN	Senegal
AU	Australia	GA	Gabon	LV	Latvia	SZ	Swaziland
AZ	Azerbaijan	GB	United Kingdom	MC	Monaco	TD	Chad
BA	Bosnia and Herzegovina	GE	Georgia	MD	Republic of Moldova	TG	Togo
BB	Barbados	GH	Ghana	MG	Madagascar	TJ	Tajikistan
BE	Belgium	GN	Guinea	MK	The former Yugoslav Republic of Macedonia	TM	Turkmenistan
BF	Burkina Faso	GR	Greece			TR	Turkey
BG	Bulgaria	HU	Hungary	ML	Mali	TT	Trinidad and Tobago
BJ	Benin	IE	Ireland	MN	Mongolia	UA	Ukraine
BR	Brazil	IL	Israel	MR	Mauritania	UG	Uganda
BY	Belarus	IS	Iceland	MW	Malawi	US	United States of America
CA	Canada	IT	Italy	MX	Mexico	UZ	Uzbekistan
CF	Central African Republic	JP	Japan	NE	Niger	VN	Viet Nam
CG	Congo	KE	Kenya	NL	Netherlands	YU	Yugoslavia
CH	Switzerland	KG	Kyrgyzstan	NO	Norway	ZW	Zimbabwe
CI	Côte d'Ivoire	KP	Democratic People's Republic of Korea	NZ	New Zealand		
CM	Cameroon		Republic of Korea	PL	Poland		
CN	China	KR	Republic of Korea	PT	Portugal		
CU	Cuba	KZ	Kazakstan	RO	Romania		
CZ	Czech Republic	LC	Saint Lucia	RU	Russian Federation		
DE	Germany	LI	Liechtenstein	SD	Sudan		
DK	Denmark	LK	Sri Lanka	SE	Sweden		
EE	Estonia	LR	Liberia	SG	Singapore		

MULTIPLE ACCESS COMMUNICATION NETWORK WITH COMBINED CONTENTION AND RESERVATION MODE ACCESS

Field of the Invention

This invention relates to communication networks and more particularly to packet based communication networks with multiple access communication channels.

5

Background of the Invention

Packet data systems are typically used for communications networks and a variety of protocols have developed to regulate transmission and receipt of data packets on such networks. As long as the ideal error-free communication channel has not been realized, data communication on such networks generally allows, among other things, for retransmission of data when errors are detected. Various protocols governing data transmission have evolved in an attempt to allow reliable data communications and to maximize network utilization. The need for optimizing channel utilization becomes even more pronounced where a heavily utilized wireless communication network such as a cellular or PCS system or a wire line network comprises a portion of the data communications network.

Typical packet data systems include a forward channel, generally referred to as a downlink (from base to portable) in a wireless network, and a reverse channel, typically referred to as an uplink (from portable to base) in a wireless network. The forward (or downlink) channel is typically a constant stream of data messages which are broadcast from a base station to a population of

20

listening subscriber devices. The forward channel is a one to many broadcast channel. The reverse channel (or uplink) is shared by the population of subscriber devices and, as a consequence, is often referred to as a many-to-one channel. This immediately highlights that the access to the reverse channel by the subscribers must be carefully managed due to the risk of multiple devices attempting to use the channel at the same instant, which results in collisions and a waste of the available bandwidth. The difficulty of channel management is exacerbated because a "listen before transmission" policy is generally hampered because the subscriber population is geographically distributed. As a consequence, subscribers may not ascertain if the reverse channel is currently being utilized by another subscriber. This is known as the hidden terminal problem.

Packet data multiple access protocols are generally classified into two categories: contention protocols (such as Aloha and CSMA) or packet reservation protocols (such as PRMA). When employed in a digital packet radio system, these systems generally employ control flags that are broadcast on the forward channel to inform the population of subscriber devices the status of the reverse channel. This approach eliminates the hidden terminal problem since all subscribers receive the forward channel. Contention schemes usually utilize a small window in which access is permitted. If a single transmission occurs, the control flags inform the remaining members of the subscriber population not to transmit, allowing the channel to become dedicated to the transmitting subscriber. However, if two transmissions occur at the same instant a collision occurs and channel bandwidth is wasted.

Packet reservation schemes manage the available channel bandwidth by either polling each subscriber in turn and dedicating the reverse channel if the subscriber has messages to transmit, or by providing a predefined periodic short contention window portion of each block in which very short reservation requests may be transmitted. Upon receipt of a successful reservation request, the channel will be allocated to the specific subscriber. The reservation transmission is regarded as very efficient since wastage due to subscriber transmission collisions generally does not occur.

In general, both categories of multiple access protocols have significant system advantages and disadvantages. The typical construction of an Aloha Contention Protocol is illustrated in FIG. 1. As illustrated in FIG. 1, synchronization words are imbedded in the forward channel at regular intervals which, in turn, delineate the reverse channel into dedicated transmission slots. A subscriber device is permitted to transmit a data packet in any slot. As a consequence, the utilization of a slot may be classified as a success, idle, or collision. A collision is defined when energy is present within slot boundaries but fails to decode which indicates that one or more transmissions from different devices probably occurred. Idle slots are devoid of energy from subscriber transmissions and successful receipt of a transmission burst from a subscriber indicates successful utilization of a slot. Collision and idle slots represent a waste of available reverse channel bandwidth.

Aloha type contention schemes generally provide for inefficient reverse channel utilization where long data packet transmissions such as file transfers are regularly encountered on the network. Such systems are also prone to instability with increasing access rates resulting in increased collisions followed by an increase in retransmission attempts which effectively continues to increase the demand on the network. Back-off policies are typically provided to reduce the risk of system instability. Aloha systems do, however, allow the use of slow receive to transmit switching time devices thereby allowing the use of low cost, half-duplex hardware.

A second type of contention scheme is a carrier sense multiple access (CSMA) protocol, the operations of which are illustrated in FIG. 2. Embedded in the forward channel is a sequence of control flags. Each control flag delineates the reverse channel into a sequence of collision windows and in addition indicates whether the reverse channel is currently being utilized (busy/idle) by a subscriber device. A subscriber device which has an outstanding data packet(s) for transmission determines if the channel is busy or idle prior to transmission. Furthermore, if the channel is sensed to be idle, the transmission occurs such that the reverse channel synchronization word is received by the base station prior to the transmission of the next busy/idle flag.

This requirement ensures that the base station is able to set the busy/idle flag to busy, thereby protecting the remaining segments of the reverse channel subscriber transmission from interference from other subscriber devices that may have outstanding data packets ready for transmission. The technique
5 allows the subscriber device to transmit variable length messages on the reverse channel without contending for the channel for each packet that requires transmission. Collisions may, however, occur during the collision window when the channel may be sensed to be idle by multiple subscribers with outstanding packets.

10 A further variant on the CSMA protocol is available if full duplex is employed. A subscriber device communicating on the reverse channel can then monitor the forward channel during the transmission of a set of data packets. The forward channel control device such as the base station can then alert a subscriber device if a collision has occurred and preempt termination of the
15 transmission thereby conserving reverse channel bandwidth that may then be exploited by a different subscriber device. This approach is typically referred to as CSMA/CD (collision detect).

A disadvantage of the CSMA scheme is the need for fast receive to transmit switching times which typically means this protocol is inappropriate for
20 use with inexpensive devices which may be desirable, particularly in a wireless environment. As CSMA is fundamentally a contention scheme, a back-off policy is typically provided as with Aloha due to the risk of system instability. An additional disadvantage of CSMA schemes is that they typically provide relatively poor channel utilization for a very short transmission packet
25 environments.

Contention based protocols are subject to instability because collisions may occur which in turn require increased attempts due to retransmission
attempts. As traffic increases, utilization of the multiple access reverse channel typically drops due to increased numbers of collisions. The collision messages
30 then are submitted for retransmission which causes the actual attempt rate (as opposed to the new arrival rate) to steadily increase without bound and once the optimal attempt rate has been passed the system utilization steadily falls.

Eventually, all transmission slots may become filled with collisions and the system utilization will reach zero. This results in both a loss of revenue bearing traffic for the channel and typically dramatically increases the delay associated with delivery of data packets. This scenario is generally referred to as Aloha or reverse channel collapse.

To prevent Aloha instability, it is known to implement back-off procedures in contention based protocols. A subscriber device is only permitted to re-transmit each packet a finite number of times. Furthermore, each re-transmission is required to be delayed by an exponentially increased delay. This back-off policy does not eliminate the possibility that system instability can occur but the possibility is significantly reduced. Furthermore, if the channel utilization does fall because the attempt rate has exceeded the maximum that the system can support, then the back-off policy provides a mechanism for recovery if instability occurs.

Back-off rules typically involve two components. First, if a transmission attempt fails then the subscriber device will delay a subsequent transmission attempt by a random time interval. Second, if the number of transmission attempts exceeds a predetermined threshold then the subscriber device will discard the queued packet and abort the transmission attempt. The first rule minimizes the possibility that two or more subscriber devices will execute re-transmission attempts after an initial collision in an identical time slot. This approach provides an effective splitting algorithm that prevents continuous repeating collisions but it does not reduce the actual attempted traffic. The second rule provides a form of non-persistence which allows the system to recover. The rule effectively increases the departure rate, and departures are now partitioned between those that are successfully transmitted and those that are abandoned.

The above stabilization procedure is generally only viable in systems where the contribution to the attempted traffic from new arrivals is essentially steady, predictable and sufficiently low so that the total attempted traffic rate can remain at or below unity. The technique can control short term transient increases in the arrival rate, which are assumed to be infrequent, and the

associated loss in channel utilization can be tolerated. However, if the number of new arrivals exceeds the departure rate (both successful and aborted) then the system may continue to drift to lower utilization. To summarize, reverse channel Aloha collapse is undesirable because the revenue stream generated by the cell is significantly reduced, subscriber devices burn excess battery power through multiple fruitless transmission attempts and message center originated messages will suffer an inordinate acknowledgment time while subscribers will be prevented from initiating and successfully transmitting a data packet.

5 An example of a packet reservation type multiple access is illustrated in
10 **FIG. 3.** The Packet Reservation Multiple Access (PRMS) schemes are typically characterized by the partitioning of the reverse channel into a polling region and a reservation/data region. The polling region includes short slots, with each slot dedicated to a specific subscriber or device. A device utilizes this slot to announce to the system that it has outstanding data packets and that
15 it requires a data slot to be reserved. If the forward channel device determines that a specific data slot within the reservation region is not utilized then it may allocate the particular data slot to a requesting reverse channel device for transmission of the outstanding frames. Ordinarily, a single data slot is commensurate with the largest possible packet or transmission block. A reverse
20 channel device may identify that the reverse channel has been exclusively reserved for it by identifying that the reservation identifier flag embedded in the forward channel has been set to its identification value. However, this approach wastes channel bandwidth for very small messages, such as system acknowledgements and polling slots that are left empty for each reverse channel
25 device that is polled but does respond because it does not have data packets to transmit. Such schemes do, however, typically allow for the use of low cost slower receive to transmit switching speed technology.

Accordingly, both contention based and reservation based multiple access communication networks generally suffer performance disadvantages where the
30 type of traffic on the network varies between short messages and long packet or file transfer type communication traffic. This problem is a particular concern for radio or wireless packet data systems such as commercial, two-way, paging

and message systems which include a mix of short and extended message traffic and typically require a protocol allowing the use of low cost technology.

Summary of the Invention

5 It is, therefore, an objective of the present invention to resolve the problem of providing for efficient utilization of channel capacity in a multiple access packet data system particularly a radio packet data system while further allowing the use of lower cost technology having relatively slow transmit to receive switching speeds. The present invention provides for a radio packet
10 data system based on a combined contention and reservation multiple access protocol to provide improved channel utilization for both short messages and long file transfers while still being adapted to low cost technology devices.

In one embodiment of an apparatus of the present invention, a forward channel is provided which includes a periodically broadcast channel control
15 packet (i.e. message) delineating the reverse channel into discrete broadcast windows. The channel control packet includes a flag designating a specific subsequent transmission window as being either a contention based transmission window or a reservation based transmission window. An identifier is also provided in the channel control packet to specify for what device a subsequent
20 reservation based transmission window has been reserved. Reverse channel transmitting devices may then transmit small data packets or optionally a request for reservation mode access to the reverse channel in any transmission window which has been designated as a contention or Aloha transmission window.

25 If a device is granted reservation access after requesting the same, longer data packets can be transmitted efficiently in reservation mode without the risk of collision from transmissions by other reverse channel transmitting devices. Furthermore, by associating each channel control packet broadcast on the forward channel with a selected subsequent reverse channel transmission
30 window, sufficient time can be provided for the use of low cost, half-duplex technology for reverse channel transmitting devices by allowing time to switch from the receive mode monitoring the forward channel control packet to the

transmit mode to transmit in the associated subsequent reverse channel transmission window.

In one embodiment of methods of the present invention, a channel access method for communicating a data packet over a multiple access communication network having a forward channel and a multiple access reverse channel is provided. A channel control packet is periodically broadcast on the forward channel. The broadcast channel control packet is received by a reverse channel transmission apparatus or subscriber device which reads the received channel control packet to determine if a contention or reservation mode is indicated. The reverse channel transmission apparatus determines if the packet to be communicated exceeds a predetermined size and transmits the data packet on the reverse channel if contention mode is indicated in the channel control packet and if the data packet size is no larger than the predetermined size. A reservation request is transmitted on the reverse channel if contention mode is indicated and if the data size exceeds the predetermined size. After transmitting a reservation request, a second one of the broadcast channel control packets is received and read to determine if reservation mode is indicated. The data packet is transmitted on the reverse channel if reservation mode is indicated in the received second one of the broadcast channel control packets.

In another aspect of methods of the present invention, a transmitted reservation request on the reverse channel is received by a forward channel transmission apparatus or base station. A channel control packet is broadcast on the forward channel responsive to the receive transmitted reservation request indicating reservation mode. In one embodiment of the present invention, the reservation request includes an identifier associated with the device transmitting the reservation request, and the step of reading the reservation request includes reading the request to determine the identifier associated with the transmitting device. It is then determined if reservation mode access to the reverse channel is available to the device transmitting the reservation request and a channel control packet is broadcast indicating reservation mode and including an access device identifier associated with the device transmitting the reservation request if it is determined that reservation mode access is available. The reverse

channel transmission apparatus reads the broadcast channel control packet to determine if its device identifier is included and reservation is indicated and, if so, the reverse channel transmission apparatus transmits its data packet.

In a further aspect of methods of the present invention, the forward channel is delineated into forward channel blocks and a channel control packet is broadcast in each block and reverse channel transmissions are synchronized to correspond to forward channel blocks. Each channel control packet is associated with a subsequent forward channel block and transmissions by subscribe devices occur in transmission windows corresponding to the forward channel block associated with the received channel control packet.

In one embodiment of methods of the present invention, each reverse channel transmission block corresponding to a forward channel block includes a plurality of contention mode transmission windows corresponding to portions of the forward channel block. Transmissions by subscriber devices occur within a selected one of the plurality of the transmission windows.

In another embodiment of methods of the present invention, the channel control packet further includes an acknowledgment status flag associated with a preceding one of the forward channel blocks indicating whether a transmission was received. A reverse channel transmission apparatus receiving a broadcast channel control packet further reads the packet to determine if an acknowledgment status flag indicates that a previous transmission was received. A preceding transmission is submitted for retransmission if the acknowledgment status flag indicates the preceding transmission was not received. In a further aspect of methods of the present invention, a plurality of reservation requests are received which requests are queued for reservation mode access to the reverse channel.

Also provided are forward channel transmission apparatus for use in a multiple access communication network having a forward channel and a multiple access reverse channel. The forward channel transmission apparatus or base station includes broadcasting means for broadcasting a channel control packet, including an indication of reservation or contention mode and an identifier, on the forward channel.

The forward channel transmission apparatus also includes receiving means for receiving a data packet or a reservation request including an identifier associated with the requesting device on the reverse channel. Optional synchronizing means synchronizes operations of the broadcasting means and the receiving means. Reading means is provided responsive to the receiving means for reading a received reservation request to determine the identifier associated with the requesting device. The forward transmission apparatus further includes determining means responsive to the reading means for determining if reservation mode access to the reserve channel is available to the requesting device and for determining if reservation mode or contention mode will be selected for the reverse channel. Generating means is provided responsive to the determining means for generating the channel control packet including setting the reservation or contention mode indication and the identifier.

In one embodiment of forward channel transmission apparatus of the present invention, the determining means determines if a data packet or reservation request has been successfully received and includes in the channel control packet an acknowledgment of successfully received packets or requests. In another embodiment, the forward channel transmission apparatus further includes means for queuing a plurality of reservation requests. In another aspect of the present invention, the forward channel transmission apparatus broadcasting means includes means for broadcasting a channel control packet in each delineated block of the forward channel to further provide for transmissions on the reverse channel synchronized to forward channel blocks. Each broadcast channel control packet is associated with and includes an indication of reservation or contention mode and subscriber device identifier which are associated with a subsequent one of the forward channel blocks.

Also provided are reverse channel transmission apparatus for use in a multiple access communication network having a forward channel and a multiple access reverse channel. The reverse channel transmission apparatus includes receiving means for receiving a channel control packet on the forward channel and reading means for reading the received channel control packet to determine if contention or reservation mode is indicated and if an identifier

associated with the reverse channel transmission apparatus is included in the channel control packet. The reverse channel transmission apparatus further includes determining means for determining if a data packet to be
5 communicated exceeds a predetermined size. The reverse channel transmission apparatus also includes means responsive to the reading means and the determining means for transmitting the data packet on the reverse channel if contention mode is indicated and if the data packet is no larger than the predetermined size and for transmitting the data packet on the reverse channel if reservation mode is indicated and if an identifier associated with the reverse
10 channel transmission apparatus is included in the receive channel control packet. Also included are means responsive to the reading means and the determining means for transmitting a reservation request on the reverse channel if contention mode is indicated and if the size of the data packet exceeds the predetermined size.

15 In another aspect of reverse channel transmission apparatus of the present invention, the apparatus includes means responsive to the reading means for submitting for retransmission a previously transmitted data packet if the previously transmitted data packet was not received. In one embodiment of the reverse channel transmission apparatus of the present invention, the forward
20 channel is delineated into forward channel blocks and transmissions by the means for transmitting data packets and the means for transmitting reservation requests are synchronized to correspond to forward channel blocks and are transmitted in selected subsequent ones of the forward channel blocks which are associated with a received channel control packet.

25 The methods and apparatus of the present invention may be beneficially utilized in wireless network environments such as a cellular radio network. They may also be beneficially utilized in a wire line data packet communication network. In addition, they are suited for use with a wired data packet communication network.

30 Accordingly, the channel access methods and forward and reverse channel transmission apparatus of the present invention address the problem of providing a reliable, high-utilization, multiple access communication channel

which may be implemented with low cost hardware. The methods and apparatus of the present invention provide efficient channel utilization for short messaging which is particularly important because link layer protocols utilize short command messages to insure successful transfer of data. The methods and apparatus of the present invention are provided by utilization of a combined contention and reservation mode access protocol which efficiently handles a mix of short message and long data transfer communication type traffic. A broadcast forward channel control packet is associated with a subsequent transmission window allowing the use of low cost slow receive to transmit switch time hardware and half-duplex transmission apparatus. Acknowledgment of successful receipt is provided to allow for data link level initiation of retransmission of lost data packets.

Brief Description of the Drawings

- 15 **FIG. 1** schematically illustrates a slotted Aloha contention protocol.
- FIG. 2** schematically illustrates a carrier sense multiple access protocol.
- FIG. 3** schematically illustrates a packet reservation multiple access protocol.
- FIG. 4** schematically illustrates an operating environment of the methods and apparatus of the present invention.
- 20 **FIG. 5** schematically illustrates an embodiment of combined contention and reservation mode operations according to an embodiment of the present invention.
- FIG. 6** is a schematic block diagram of a forward channel transmission apparatus according to the present invention.
- 25 **FIG. 7** is a schematic block diagram of a reverse channel transmission apparatus according to the present invention.
- FIG. 8** is a flowchart illustrating operations of a reverse channel transmission apparatus according to a channel access method of the present invention.
- 30

FIG. 9 is a flowchart illustrating operations of a forward channel transmission apparatus according to a channel access method of the present invention.

FIG. 10 schematically illustrates operations of an embodiment of the channel access methods and apparatus of the present invention.

FIG. 11 schematically illustrates an embodiment of a channel access method and apparatus of the present invention including a decode status bit mask for acknowledgment of successfully transmitted packets and a dynamic access control parameter.

FIG. 12 schematically illustrates an embodiment of a forward channel structure according to the present invention.

FIG. 13 schematically illustrates an embodiment of a reverse channel structure in contention mode according to the present invention.

FIG. 14 schematically illustrates an embodiment of the reverse channel structure in reservation mode according to the present invention.

FIG. 15 schematically illustrates contention mode timing requirements according to an embodiment of the present invention.

FIG. 16 schematically illustrates reservation mode access timing requirements according to an embodiment of the present invention.

FIG. 17 schematically illustrates reservation/contention flag and reservation identification procedures according to an embodiment of the present invention.

FIG. 18 schematically illustrates an embodiment of dynamic access control according to the present invention.

FIG. 19 is a flowchart illustrating operations for dynamic access control according to an embodiment of the present invention.

FIG. 20 is a flowchart illustrating back-off operations for use with the dynamic access control methods and apparatus of the present invention.

FIG. 21 is a flowchart illustrating operations for determination of a probability of transmission parameter for an embodiment of a dynamic access control method and apparatus according to the present invention.

FIG. 22 is a state diagram for a subscriber device according to an embodiment of the present invention.

FIG. 23 is a state diagram for a base station according to an embodiment of the present invention.

FIG. 24 schematically illustrates operations over time for an Aloha system with back-off rules providing recovery.

5 FIG. 25 schematically illustrates operations over time for an Aloha system where back-off rules fail to provide for recovery.

Detailed Description of Illustrated Embodiments

The present invention now will be described more fully hereinafter with reference to accompanying drawings, in which preferred embodiments of the invention are shown. This invention may, however, be embodied in many
10 different forms and should not be construed as limited to the embodiments set forth herein; rather, these embodiments are provided so that this disclosure will be thorough and complete, and will fully convey the scope of the invention to those skilled in the art.

15 Referring now to FIG. 4, an operating environment of the present invention is schematically illustrated. Shown in FIG. 4 are fixed end systems and a router device in a hardwired internet network 20. Hardwire network 20 is connected to radio network controllers 22, 22'. Each controller 22, 22' controls one or more base stations 24, 24'. As illustrated in FIG. 4, base
20 stations 24, 24' are radio communication network base stations associated with cells of cellular networks indicated as cell A, cell B, cell C, cell 1, cell 2 and cell 3, respectively. Base stations 24, 24' are forward channel transmission apparatus which receive communications on one or more multiple access reverse channels. Each base station 24, 24' may support one or more reverse
25 channels.

Base stations 24, 24' establish radio data packet communications with subscriber devices 26, 26'. Subscriber devices 26, 26' are reverse channel transmission apparatus which receive transmissions from base station 24, 24' on a forward or downlink channel and transmit to base stations 24, 24' on a
30 multiple access reverse or uplink channel.

Controllers 22, 22' and base stations 24, 24' may, for example, comprise a paging and messaging system. Controllers 22, 22' interface the radio network

to hardwire network 20 and provide mobility management by constructing and updating a directory or routing table to map an internet IP address of subscriber device 26, 26' to a specific temporary address and channel stream identifying a current connection for subscriber device 26, 26' through one of base stations 24, 24'. Communications between internet fixed end systems and subscriber devices 26, 26' may then be made transparent to the fixed end systems.

Overview of the Invention

Existing packet radio systems are designed to support specific applications which exhibit well defined data packet sizes and traffic profiles. Methods and apparatus of the present invention can support and adapt to a varying range of packet sizes and traffic profiles while achieving a high channel utilization. This is desirable in a public/commercial system which supports a multitude of different applications. Although it is generally difficult to predetermine the exact traffic profiles prior to commercial service, it is possible to identify prominent characteristics. In general, data transactions are either network 20 or subscriber device 26 originated. Network originated traffic primarily generates reverse channel traffic in the form of short system acknowledgments indicating the receipt of a data packet. In contrast, subscriber originated data transactions utilize the reverse channel to deliver messages of varying sizes. Exact packet sizes typically cannot be predetermined due to the unpredictable nature of each application that may utilize the system. In addition, as subscriber device 26 migrates throughout the radio network, very short location update/cell transfer messages are preferably transmitted in an efficient manner. Therefore, the reverse channel traffic is typically polarized between a single, fixed size acknowledgment message and data packet messages that are variable in size and have a somewhat larger minimum size.

The present invention provides a contention mode suited to short messages and ensures that both upper layer management, connection and application protocols can correctly execute by transmitting longer frames. The inclusion of a contention free reservation mode enables devices to transmit extended messages that are not limited to a single data packet. Furthermore, reservation

mode allows the reverse channel utilization to arbitrarily approach 100% as the message length is extended.

The present invention consists of a forward channel data stream (broadcast by the base station) that is delineated into forward channel blocks (the data contained in each block is ordinarily protected against channel impairments and errors by an error detecting and correcting FEC code). The block boundaries are identified by the inclusion of a forward channel synchronization word within each block. Furthermore, embedded in each block is an Reservation/contention flag and a Reservation Identifier. The Reservation/contention flag is used to indicate to the population of subscriber devices that the reverse channel is available for contention access or whether it has been allocated to a specific device for a reservation transmission.

The reverse channel transmissions may be categorized as a contention burst, or as reservation block or multiple reservation block transmissions. The reverse channel transmissions are synchronized to the forward channel block intervals which may support a plurality of contention burst transmissions that are tightly synchronized to fall within slot boundaries, or a single reservation block transmission. The contention transmission bursts are designed to support acknowledgment messages to the forward channel traffic, reservation requests and all short system protocol exchanges. The reservation block length is designed to support a single data packet (minimum length) that may be transmitted by a subscriber originated data transaction.

To enable slow receive to transmit (and vice versa) switching times, the forward channel Reservation/contention and Reservation Identifier flags correspond to reverse channel traffic that will occur in a subsequent block(s). Preferably, a 2 block delay is provided to ensure that a low cost radio technology may be employed. However, depending upon system requirements the delay may be reduced to a single block interval or, conversely extended to provide further switching time. Subscriber device 26 secures a reservation transmission by first transmitting a reservation request embedded in a contention burst to base station 24. The reservation request specifies the exact number of reverse channel block intervals that are required to transmit an

outstanding set of data packets which constitute a subscriber originated transaction. If base station 24 determines that the reservation may be granted, subscriber device 26 will observe that the forward channel Reservation/contention flag and Reservation Identifier are set to indicate that the reservation transmission may commence.

The present invention may be efficient because the reservation scheme allows an arbitrary unconstrained number of reverse channel block intervals to be potentially assigned to a specific subscriber device 26. The invention need not sacrifice bandwidth by requiring that a fixed predetermined number of block intervals cannot be fully utilized by the reservation request, as is common with existing reservation protocols. Moreover, the present invention may adapt to the specific traffic profile observed by base station 26. That is, if the traffic profile is biased towards contention traffic, the reverse channel is predominantly operated in the contention mode. Alternatively, if the reverse channel traffic reflects a significant volume of extended length messages, the reservation mode is more heavily utilized.

Referring now to FIG. 5, the framing of the forward and reverse channels according to an embodiment of the present invention is illustrated. As illustrated in FIG. 5, the forward channel stream is delineated into a series of transmission windows. Each transmission window includes a synchronization transmission, a Reservation/contention flag and a Reservation ID. For purposes of understanding the present invention, the description shall be based on an Aloha type contention mode and the terms "contention" and "Aloha" will be used interchangeably throughout the balance of this detailed description unless specifically noted. The Reservation (resv.) or Aloha state for a corresponding subsequent transmission window is indicated by bold. As illustrated in the embodiment of FIG. 5, the Reservation/Aloha flag in each block corresponds to a subsequent block, two blocks removed (*i.e.*, block 1 corresponds to block 3 transmission on the reverse channel). The reverse channel transmissions illustrated in FIG. 5 include short Aloha bursts corresponding to block 3 and reservation bursts corresponding to blocks 7, 8 and 9. In the embodiment

illustrated in FIG. 5, contention transmission windows are broken into 3 separate transmission slots.

Apparatus of the Present Invention

5 Referring now to FIG. 6, an embodiment of a forward channel transmission apparatus or base station 24, according to the present invention, is illustrated. Base station 24 includes transmitter 30 or other broadcasting means for broadcasting a channel control packet on the forward channel. As illustrated in FIG. 5, base station 24 is a component of a radio data packet network
10 including a forward channel having a wireless (radio) communication link in the forward and reverse channels. However, it is to be understood that the benefits of the present invention can also be obtained in a network including a wireline or wired network so long as base station or forward channel transmission apparatus 24 is operatively connected to the forward and reverse channels.

15 Receiver 32 or other receiving means for receiving a data packet and for receiving a reservation request on the reverse channel are also included in base station 24. Receiver 32 in the embodiment illustrated in FIG. 6 is also operatively connected to a wireless (radio) reverse channel. It is to be understood that while transmitter 30 and receiver 32 are illustrated as separate
20 components capable of full duplex operation, the benefits of the present invention may also be obtained using a transceiver combining the operations of transmitter 30 and receiver 32. Timer 34 or other synchronizing means provides for synchronizing operations of transmitter 30 and receiver 32.

Base station 24 also includes packet receipt circuit 36 or other reading
25 means responsive to receiver 32 for reading a reservation request to determine the identifier associated with the requesting subscriber device 26. Packet receipt circuit 36 also reads data packets received via receiver 32 from transmitting subscriber device 26. Channel control circuit 38 or other determining means responsive to packet receipt circuit 36, determines if
30 reservation mode access to the reverse channel is available to requesting subscriber device 26 and determines if reservation mode or contention mode will be selected for the reverse channel in a subsequent transmission window.

Packet transmit generation circuit 40 or other generating means responsive to channel control circuit 38 generates the channel control packet including setting the reservation or contention mode indication and the identifier associated with a selected subscriber device 26. As illustrated in FIG. 6, packet receipt circuit 5 36, channel control circuit 38 and packet transmit generation circuit 40 can be combined into base station control circuit 42. Base station control circuit 42 interfaces to a data link entity (not shown) which receives and transmits data packets through base station 24. Referring to FIG. 4, base station 24 may interface to a fixed end system associated data link entity through controller 22.

10 In one embodiment of a forward channel transmission apparatus of the present invention, as illustrated in FIG. 6, channel control circuit 38 further includes means for determining if a received data packet or reservation request has been successfully received. In this embodiment, packet transmit generation circuit 40 further includes generating means for generating a channel control 15 packet which includes an acknowledgment of successfully received data packets or reservation requests. In another aspect of the present invention, channel control circuit 38 further includes means for queuing a plurality of received reservation requests.

As illustrated in FIG. 5, the forward channel is delineated into forward 20 channel blocks. In this embodiment, packet transmit generation circuit 40, as illustrated in FIG. 6, includes means for broadcasting one of the channel control packets in each of the forward channel blocks. As the reverse channel transmissions are synchronized to correspond to the forward channel blocks, timer 34 synchronizes receiver 32 and transmitter 30 for reverse channel receipt 25 timing. Furthermore, channel control circuit 38 and packet transmit generation circuit 40 broadcast channel control packets including an indication of reservation or contention mode and an identifier which are associated with a subsequent one of the forward channel blocks. Similarly, indications in the broadcast channel control packet of successfully received packets on the reverse 30 channel are associated with a preceding one of the forward channel blocks.

As will be appreciated by those of skill in the art, the above described aspects of the present invention in FIG. 6 may be provided by hardware,

software, or a combination of the above. While the various components of forward channel transmission apparatus or base station 24 have been illustrated in FIG. 6 as discrete elements, they may, in practice, be implemented by a microcontroller including input and output ports and running software code, by custom or hybrid chips, by discrete components or by a combination of the above. For example, packet receipt circuit 26, channel control circuit 38 and packet transmit generation circuit 40 could all be implemented as a single programmable device.

Referring now to FIG. 7, an embodiment of a reverse channel transmission apparatus or subscriber device 26 according to the present invention is illustrated. Subscriber device 26 includes receiver 44 or other receiving means for receiving a broadcast channel control packet. Receiver 44 also provides means for receiving data packets transmitted from base station 24. Subscriber device 26 further includes packet receipt circuit 46 or other reading means for reading received channel control packets to determine if a contention or a reservation mode is indicated and if an identifier associated with subscriber device 26 is included in the received channel control packet. In one embodiment of the reverse channel transmission apparatus of the present invention, packet receipt circuit 46 further includes means for reading an acknowledgment status flag in the channel control packet to determine if a previously transmitted data packet was received.

Subscriber device 26 also includes channel control circuit 48 or other determining means for determining if a data packet to be communicated exceeds a predetermined size. Packet transmit generation circuit 50 or other means responsive to packet receipt circuit 46 and channel control circuit 48 for transmitting a data packet on the reverse channel either if contention mode is indicated and the data packet is no larger than the predetermined size or if reservation mode is indicated and an identifier associated with the reverse channel transmission apparatus 26 is included in the received channel control packet is also provided. Packet transmit generation circuit 50 further provides means responsive to packet receipt circuit 46 and channel control circuit 48 for transmitting a reservation request on the reverse channel if contention mode is

indicated and the size of the data packet to be transmitted exceeds the predetermined size.

Timer 52 or other synchronizing means is provided for synchronizing the operations of receiver 44 and transmitter 54. Transmitter 54 operates
5 responsive to packet transmit generation 50 to provide means for transmitting data packets and reservation requests on the reverse channel. As illustrated in FIG. 7, packet receipt circuit 46, channel control circuit 48, and packet transmit generation circuit 50 may be combined in subscriber device control circuit 56.

10 In one embodiment of the reverse channel transmission apparatus of the present invention as illustrated in FIG. 5, the forward channel is delineated into forward channel blocks. Transmissions by transmitter 54 are synchronized to correspond to the forward channel blocks as detected from transmissions received by receiver 44 and packet receipt circuit 46. Transmission of data
15 packets and reservation requests by transmitter 54 and packet transmit generation circuit 50 are provided in selected subsequent ones of the forward channel blocks which are associated with the received channel control packets. Subscriber device 26 through subscriber device control circuit 56 is operatively connected to a datalink entity (not shown) which is receiving and transmitting
20 data packets over the radio communications network.

As will be appreciated by those of skill in the art, the above described aspects of the present invention in FIG. 7 may be provided by hardware, software, or a combination of the above. While the various components of reverse channel transmission apparatus or subscriber device 26 have been
25 illustrated in FIG. 7 as discrete elements, they may, in practice, be implemented by a microcontroller including input and output ports and running software code, by custom or hybrid chips, by discrete components, or by a combination of the above. For example, packet receipt circuit 46, channel control circuit 48, and packet transmit generation circuit 50 could all be
30 implemented as a single programmable device.

Overview of the Methods of the Present Invention

Referring now to FIG. 8, an embodiment of operations for channel access for communicating a data packet over a multiple access communication network having a forward channel and a reverse channel according to the present invention will be described. More particularly, FIG. 8 illustrates operations of a method according to the present invention as executed by a reverse channel transmission apparatus 26. At block 60, one of the broadcast channel control packets is received and read by subscriber device 26 to determine if contention or reservation mode is indicated. If contention mode is indicated at block 62 and the data packet size to be transmitted is no larger than the predetermined size at block 64, the data packet is transmitted as a short burst in contention mode at block 66. If it is determined that contention mode is indicated at block 62 and determined at block 64 that the data packet to be communicated exceeds a predetermined size, at block 68 a reservation request is transmitted on the reverse channel. If reservation mode is indicated at block 62 and if the control packet read at block 60 includes an identifier associated with the receiving subscriber device 26 at block 70, the data packet or packets are transmitted in reservation mode at block 72.

In one embodiment of methods of the present invention, the control packet received at block 60 further includes an acknowledgment indication (status flag) for previously transmitted data packets or reservation requests. The received acknowledgment status flag corresponds to a preceding one of the channel transmission windows. At block 74, subscriber device 26 determines if it has any outstanding data packets or reservation requests requiring acknowledgment. If so, at block 76, subscriber device 26 determines from the acknowledgment status flag or flags of the received channel control packet if the previous transmission was received. At block 78, if the previous transmission is not acknowledged, it is submitted for retransmission.

Referring now to FIG. 9, operations of an embodiment of the channel access methods of the present invention will be further described as executed by a forward channel transmission apparatus or base station 26. At block 80, a channel control packet is broadcast on the forward channel. At block 82, base

station 24 monitors the reverse channel for transmissions from subscriber devices 26. Base station 24 may receive a transmitted reservation request or a data packet on the reverse channel at block 82. A collision may also be detected at block 82. If it is determined at block 84 that a data packet rather than a reservation request has been received, the data packet is received and read at block 86.

If it is determined at block 84 that a reservation request has been received at block 82, the reservation request is read at block 88 to determine the identifier associated with the subscriber device 26 transmitting the reservation request.

At block 90, base station 24 determines if reservation mode access to the reverse channel is available to the subscriber device 26 transmitting the reservation request. At block 92, a channel control packet is generated for transmission responsive to the received reverse channel transmission. If it is determined at block 90 that reservation mode access is available to the requesting subscriber device 26, the generated channel control packet which will be subsequently transmitted at block 80, as indicated by the looping path reflecting periodic transmission of channel control packets, is generated to indicate reservation mode and to include an access device identifier associated with the device transmitting the reservation request.

In one embodiment of methods of the present invention, the forward channel is delineated into forward channel blocks and the operations of FIG. 9 are repeated for each forward channel block. In another embodiment of methods of the present invention, reservation requests from subscriber device 26 further include an indication of the size of the data packet to be transmitted.

Reservation mode access to any one requesting subscriber device 26 is made available by base station 24 for no more than a predetermined maximum number of forward channel block transmission windows on the reverse channel for any single reservation request. This embodiment allows base station 24 to control the amount of reservation mode access allocated to any individual subscriber device 26. In another embodiment, reservation mode access operations at block 90 include queuing a plurality of received transmitted reservation requests for reservation mode access to the reverse channel.

In an additional aspect of methods of the present invention, as illustrated in FIG. 9, base station 24 provides acknowledgment of received data packets. At block 86, when a data packet is successfully received, an acknowledgment status flag is set which is included at block 92 when the channel control packet for transmission is generated. The acknowledgment status flag in the generated channel control packet is associated with a specific previously transmitted data packet and indicates successful receipt of the data packet.

As is illustrated in the embodiment of FIG. 5, and more specifically with respect to illustrated blk 3, the reverse channel blocks may be broken into a plurality of contention mode transmission windows. Subscriber device 26 at block 66 and at block 68 of FIG. 8 selects one of the predetermined number of contention mode transmission windows corresponding to portions of the forward channel block designated for contention mode transmission and transmits the data packet or reservation request, respectively, in the selected one of the plurality of transmission windows.

Detailed Description of Operations of the Channel Access Methods and Apparatus of the Present Invention

Referring now to FIG. 10, channel access procedures according to an embodiment of methods and apparatus of the present invention will now be described. As illustrated in FIG. 10 at blk N-2, subscriber device 26 examines the Reservation/contention (rsvr/Aloha) flag to determine its state, which is indicated in bold as Aloha in FIG. 10. Accordingly, subscriber device 26 transmits a short data packet or reservation request in a randomly selected one of the three Aloha burst slots indicated as x, y, and z in blk N. Otherwise, subscriber device 26 waits to transmit its request for a subsequent forward channel block. By sending the reservation/contention flag two block intervals early, subscriber device 26 is allowed a minimum of a one full block interval to switch from receive to transmit. It is preferable that subscriber device 26 selects one of the three Aloha burst transmission windows at random to minimize the risk of a collision with another transmitting subscriber device 26.

If the data packet to be transmitted is too long for inclusion in a single contention transmission window, a reservation request is sent indicating the amount of reverse channel bandwidth required to be allocated to subscriber device 26 to transmit the outstanding data packet(s). If base station 24 accepts the reservation request and determines reservation mode access is available, subscriber device 26 is notified via the forward channel two block intervals later as indicated in FIG. 10 at blk N+2. Subscriber device 26 then determines that the reservation request has been successful by observing that the reservation/contention flag has been set to reservation and that the reservation identifier (id-subscriber in blk N+2) reflects the associated identifier of the requesting subscriber device 26. This, once again, provides the minimum one block interval switching time from transmit to receive for subscriber device 26. The reservation flag is not set to reservation by the forward channel transmission apparatus 24 until blk N+2 (even though base station 24 may, as a full duplex device have received it, and been in a position to set the reservation flag in blk N+1) so that sufficient time is allowed for switching from transmit to receive by subscriber device 26. The data packet is then transmitted by subscriber device 26 beginning at blk N+4 and continuing with the required number of additional blocks which, as illustrated in FIG. 10, include blk N+5 and blk N+6 for the reservation mode transmission from subscriber device 26.

As illustrated further in the embodiment shown in FIG. 11, methods and apparatus of the present invention further provide a low layer decode status mechanism to initiate correction of failed transmissions prior to the invocation of higher layer recovery mechanisms to thereby reduce channel utilization for transmission of repeat request packets which are typically required by higher layer recovery mechanisms. Lost data packets may then be retransmitted and successfully received before higher layer recovery mechanisms initiate retransmission requests with the associated overhead and channel utilization thereof.

As illustrated in FIG. 11, a channel access status octet is transmitted in each forward channel block. Typically, each of these transmissions is further protected by a forward channel error correcting strategy which strategies are

known and understood by those of ordinary skill in the art and will not be discussed further herein. As illustrated in FIG. 11, the channel access status octet is partitioned with a six bit decode status bit mask and a two bit channel access mode field. The first three bits of the decode status bit mask indicate the success or failure of the Aloha transmissions received on the reverse channel that correspond to the forward channel block interval transmitted two blocks prior to the current forward channel block interval. The second three bits indicate the success or failure of the Aloha transmissions received on the reverse channel that correspond to the forward channel block interval that was transmitted at three block intervals prior to the current block interval.

The second three bits of the decode status bit field represent status information that is being retransmitted for the second time. This repetition allows a subscriber device 26 that is, for example, experiencing a ten percent forward channel error rate to achieve a one percent indeterminate rate in the decode status information. Accordingly, on receipt of a decode status failure or two indeterminate decode status bit mask blocks, subscriber device 26 attempts to submit for retransmission the data packet or reservation request. If an Aloha burst is not received or the base station services a reservation request and receives reservation blocks, then the base station will set the Decode Status bits to failure.

A typical scenario is illustrated in FIG. 11. The following procedure may be used to determine the setting of the Decode Status bits in the Channel Access Status word. For the purposes of this procedure, base station 24 maintains a counter that increments as each forward channel block is encoded and transmitted. Base station 24 sets the Decode Status bits in the Channel Access Status word that is encoded and transmitted in the N^{th} forward channel Reed Solomon block according to the following rules:

30	IF	an Aloha burst was received in slot 1 on the reverse channel and correctly decoded while the (N-2)nd block was transmitted on the forward channel
	THEN	Base station 24 sets b_{11} of the Channel Access Status word to indicate success (1)
	IF	an Aloha burst was received in slot 2 on the reverse channel and correctly decoded while the (N-2)nd block was transmitted on the forward channel

-27-

THEN Base station 24 sets b_{10} of the Channel Access Status word to success (1)

IF an Aloha burst was received in slot 3 on the reverse channel and correctly decoded while the (N-2)nd block was transmitted on the forward channel

5 THEN Base station 24 sets b_9 of the Channel Access Status word to indicate success (1)

IF an Aloha burst was received in slot 1 on the reverse channel and correctly decoded while the (N-3)rd block was transmitted on the forward channel

10 THEN Base station 24 sets b_8 of the Channel Access Status word to indicate success (1)

IF an Aloha burst was received in slot 2 on the reverse channel and correctly decoded while the (N-3)rd block was transmitted on the forward channel

15 THEN Base station 24 sets b_7 of the Channel Access Status word to indicate success (1)

IF an Aloha burst was received in slot 3 on the reverse channel and correctly decoded while the (N-3)rd block was transmitted on the forward channel

20 THEN Base station 24 set b_6 of the Channel Access Status word to indicate success (1)

IF a reservation block was received on the reverse channel while the (N-2)nd block was transmitted on the forward channel

25 THEN Base station 24 sets b_{11} , b_{10} and b_9 of the Channel Access Status word to indicate failure (0)

IF a reservation block was received on the reverse channel while the (N-3)rd block was transmitted on the forward channel

30 THEN Base station 24 sets b_8 , b_7 and b_6 of the Channel Access Status word to indicate failure (0)

IF Base station 24 determines that specific reservation requests received on the reverse channel while the (N-2)nd block was transmitted on the forward channel shall be discarded

35 THEN Base station 24 sets b_{11} and/or b_{10} and/or b_9 of the Channel Access Status word to indicate failure (0)

IF Base station 24 determines that specific reservation requests received on the reverse channel while the (N-3)rd block was transmitted on the forward channel shall be discarded

40 THEN Base station 24 sets b_8 and/or b_7 and/or b_6 of the Channel Access Status word to indicate failure (0)

ELSE Base station 24 sets the decode status bits of the Channel Access Status word to indicate failure (0)

As illustrated in FIG. 11, the channel access mode or reservation/contention flag is provided as a two bit channel access field. This embodiment provides four operation modes to allow base station 24 to adaptively set modes to reflect actual traffic flow on the network. These modes, as illustrated in FIG. 11, include mode 1 (01), a contention mode with short reservation mode access only allowed (*i.e.*, for example, limited to one to two blocks of reservations transmission per request). This mode may be desirable when the traffic profile for a particular channel is heavily biased toward short numeric and alpha paging on the forward channel. A second mode, mode 2(10) is contention and reservation mode without queuing, but allowing longer reservation mode blocks. This mode is typically preferred when the traffic profile for a particular cell is biased towards forward channel messaging. Allowing only one reservation request at a time to be accepted provides twelve contention burst occurrences between every reservation transmission in the embodiment as illustrated in FIG. 9 where three Aloha bursts are allowed in each forward channel block. A final mode, mode 3 (11) is contention mode combined with queued reservations. This mode is preferably utilized when the traffic profile for a particular cell is biased towards extended reverse channel messaging. It is preferred that the actual traffic profile for a network be considered for each reverse channel stream and the specific operating mode selected be determined so as to optimize the reverse channel utilization.

Referring now to FIG. 12, the forward channel structure for an embodiment of methods and apparatus of the present invention will be described. It is to be understood that the particular encoding and bit breakdown of the illustrated forward channel structure is merely illustrative.

As illustrated in FIG. 12, the forward channel includes a sequence of 432 bit transmission blocks. Each block contains a 27 bit synchronization sequence and a 27 bit reservation identifier which are interleaved with a 378

Reed Solomon forward error correcting code. The 1 bit Reservation/Aloha flag is "exclusive-or"ed with the 27 bit forward channel synchronization word.

The forward channel Reed Solomon block consists of parity symbols and data symbols. The Reed Solomon code is a (63,51) code which is partitioned between 12 RS parity symbols and 51 RS data symbols. The data field is
5 partitioned between the data field that is utilized for system messages and the channel access status word, channel operation word and color code.

The channel access status word is a 12 bit/2 Reed Solomon symbol word that contains the decode status bits, channel mode bits and the probability of
10 transmission parameter. The channel operation word is a 4 bit/ 2/3 Reed Solomon symbol word that contains the channel capacity flag and additional system specific parameters. The color code may be employed in a radio environment to distinguish different transmission channels.

As illustrated in **FIG. 13**, the reverse channel Aloha transmission burst
15 includes a 132 bit transmission burst. Each Aloha burst contains a 6 bit synchronization sequence that is split into two 3-bit words that are interleaved with a 126 shorted Reed Solomon forward error correcting code. The Reed Solomon code is a (63,57) code which is partitioned between 6 RS parity symbols, 15 RS data symbols and 42 all Zero RS data symbols which are not
20 transmitted. The Aloha transmission burst may contain a Reservation request or a short data message. A non-uniform distribution of the synchronization words throughout the Aloha transmission burst is provided. Additional synchronization words are placed at the beginning of the burst to assist in rapid acquisition of a transmission from subscriber device **26** by base station **24**.

As illustrated in **FIG. 14**, the reverse channel Reservation transmission
25 block includes a 420 bit transmission block. Each Reservation transmission block contains a 42 bit synchronization sequence that is split into fourteen 3-bit words that are interleaved with a 378 Reed Solomon forward error correcting code. The Reed Solomon code is a (63,55) code which is partitioned between 8
30 RS parity symbols, 55 RS data symbols. A non-uniform distribution of the synchronization words throughout the Reservation transmission block is provided. Additional synchronization words are placed at the beginning of the

burst to assist in rapid acquisition of a transmission from subscriber device 26 by base station 24.

If subscriber device 26 has outstanding data packets for transmission, it is initially required to achieve synchronization with the forward channel and determine the reverse channel state from the Reservation/Aloha flag and the channel access status word that is encoded within each forward channel FEC block. If the reverse channel is available for Aloha access, subscriber device 26 may proceed to attempt access to the reverse channel.

Subscriber device 26 will initially assess whether the outstanding data packets may be compressed into a single Aloha transmission burst. Alternatively, subscriber device 26 will encode the data packets into a sequence of Reservation blocks and construct an Aloha reservation request burst indicating the number of reverse channel block intervals that are required for the reservation transmission. The burst is transmitted in one of the three available Aloha slots. As illustrated in FIG. 15, to enable half duplex subscriber devices 26 that employ a receive to transmit (and vice versa) switch time that is commensurate with a forward channel block duration, transmissions are delayed by two forward channel block intervals. Although an extended time period is allocated for the device to switch from receive to transmit, the actual transmission instant is preferably relatively tightly specified. This ensures that reverse channel bandwidth is efficiently utilized by allowing guard time, power ramp and synchronization overhead to be minimized.

Subscriber device 26 determines whether an Aloha transmission burst is successful by observing the decode status bits in the channel access status word that is embedded in the forward channel Reed Solomon block transmitted two forward channel block durations after the Aloha transmission occurred. If the forward channel Reed Solomon block is corrupted due to poor channel conditions, the decode status bits are also replicated by base station 24 in the subsequent channel access status word that is transmitted in the next forward channel Reed Solomon block. If subscriber device 26 determines that the transmission was successful, subscriber device 26 may terminate the channel access procedures. Alternatively, if the transmission attempt was a failure due

to the decode status bit indicating failure or was declared indeterminate due to decoding failures, subscriber device 26 will initiate a re-transmission attempt.

Depending upon the operating mode that is utilized by base station 24, subscriber device 26 may or may not be able to immediately determine the success of the reservation request. When Mode 1 or 2 (see FIG. 11) are employed, a single reservation request is serviced and additional requests for bandwidth are not queued. Therefore, the success of an Aloha reservation request may be immediately determined by examining the Reservation Identifier and Reservation /Aloha flag transmitted two forward channel block intervals after the Aloha reservation request was transmitted. However, in Mode 3 (see FIG. 11), reservations are queued. Thus subscriber device 26 is required to examine the decode status bits and, if success is indicated, delay a re-transmission attempt of the Aloha reservation request until it is confirmed that the reservation queue is empty. If the reservation is granted, subscriber device 26 will initiate transmission of the previously encoded Reed Solomon blocks. In a similar manner to an Aloha transmission, subscriber device 26 is required to delay transmission by two forward channel block durations.

Subscriber device 26 timing requirements for the transmission of an Aloha burst are also illustrated in FIG. 15. A significant period of time is allocated to enable an extended receive to transmit switching time, receiver and DSP filter propagation delays, and demod/modulator processing delays. However, despite the extended processing period, the tolerance of the transmission instant as illustrated in the embodiment of FIG. 15 is defined to an accuracy of ± 0.25 bit times. This provides 1.5 bit intervals ($187.5\mu\text{s}$) to be allocated to free space propagation delay.

Subscriber device 26 timing requirements for the transmission of a 428 bit Reed Solomon reservation block are illustrated in FIG. 16. A significant period of time is allocated to enable an extended receive to transmit switching time, receiver and DSP filter propagation delays, and demod/modulator processing delays. However, despite the extended processing period, the tolerance of the transmission instant as illustrated in the embodiment of FIG.

16 is defined to an accuracy of ± 0.25 bit times. This provides 1.5 bit intervals (187.5 μ s) to be allocated to free space propagation delay.

Referring now to FIG. 17, details of procedures for the use of the Reservation/Aloha flag and Reservation Identifier of the channel control packet for an embodiment of the present invention will be further described. The Reservation/Aloha flag and Reservation Identifier are transmitted once in each forward channel block. The position of the 27 bit Reservation Identifier and 27 bit Reservation/Aloha flag are illustrated in FIG. 17. The Reservation/Aloha flag as illustrated is "exclusive or"ed with the 27 bit forward channel synchronization word.

The purpose of the Reservation/Aloha flag is to inform the population of subscriber devices 26 that are currently registered or using the channel that the reverse channel is available for slotted Aloha access on a contention basis, or that the reverse channel has been reserved for a specific subscriber device 26. To provide subscriber devices 26 with at least one forward channel block interval receive to transmit switch time, the Reservation/Aloha flag is set two forward channel blocks in advance of the actual associated reverse channel transmission window.

The Reservation Identifier is primarily utilized to identify a specific subscriber device 26 for which the reverse channel has been allocated from a small subset of subscriber devices 26 for which reservation requests may be queued. In a similar manner to the Reservation /Aloha flag, the Reservation Identifier is set two blocks in advance of the anticipated subscriber transmission. However, as illustrated in the embodiment of FIG. 17, the Reservation Identifier is also set by base station 24 to indicate that the reservation is in progress in the first block subsequent to receipt of a reservation request. When the system is operating in Mode 2 (Aloha and Serve One at Random) this is utilized in conjunction with the Reservation/Aloha flag by the population of subscriber devices 26 to determine if the transmission of a reservation request should be temporarily delayed. This measure conserves subscriber device power consumption and channel capacity.

An additional feature of the procedures governing the Reservation Identifier is also illustrated in FIG. 17. In the first and subsequent forward channel blocks after a subscriber specific Reservation Identifier has been transmitted, base station 24 sets the Reservation Identifier to the reservation in progress value. This prevents the subscriber device 26 for which the channel has been reserved from transmitting exactly one or more blocks later than required if the first Reservation Identifier is missed. This is desirable because base station 24 has reserved a specific number of reverse channel blocks for that subscriber device. Asynchronous transmission could potentially cause a collision with subsequent Aloha or queued reservation transmissions. The procedure also affords an additional advantage because the Reservation Identifier, in combination with the Reservation/Aloha flag, may be employed by the subscriber device 26 population to construct an effective 48 bit Reservation/Aloha flag that is extremely robust and tolerant to an errored channel. This approach significantly minimizes the number of occurrences in which a subscriber device 26 initiates an Aloha transmission while a reservation session is currently in progress.

Base station 24 may operate in a variety of modes as illustrated in FIG. 11. In general, the procedures for the Reservation/Aloha Flag are independent of which operating mode is utilized by base station 24. Ordinarily, the Reservation/Aloha flag is set to reservation two forward channel block intervals prior to the reverse channel transmission by subscriber device 26. Furthermore, the Reservation/Aloha flag is reset two blocks prior to the termination of the reverse channel transmission by subscriber device 26. The flag may be reset to indicate Aloha or Reservation depending upon which operating mode is utilized by base station 24. For the purposes of these procedures, base station 24 maintains a counter that increments as each forward channel block is encoded and transmitted. A typical scenario is illustrated in FIG. 17. Base station 24 sets the Reservation / Aloha flag that is encoded and transmitted in the Nth forward channel block according to the following rules:

IF a reservation request was received on the reverse channel and granted while the (N-2)nd block was transmitted on the forward channel
 THEN Base station 24 sets the Reservation / Aloha Flag to indicate Reservation

-34-

IF Base station 24 determines that a reserved transmission by a subscriber device 16 will terminate during the $(N + 1)^{\text{th}}$ forward channel block interval
 THEN Base station 24 examines the reservation queue

5 IF Base station 24 determines that one or more reservation requests are still outstanding
 THEN Base station 24 resets the Reservation / Aloha flag to reserved
 ELSE Base station 24 resets the Reservation / Aloha flag to Aloha

IF Base station 24 determines that a reserved reverse channel transmission by a subscriber device 26 was absent during the $N-1$ forward channel block interval
 10 THEN Base station 24 examines the reservation queue

IF Base station 24 determines that one or more reservation requests are still outstanding
 THEN Base station 24 resets the Reservation / Aloha flag to reserved
 ELSE Base station 24 resets the Reservation / Aloha flag to Aloha

15

In general, the procedures for the Reservation Identifier are also independent of which operating mode is utilized by base station 24. Ordinarily, the Reservation Identifier is set to identify a specific device two forward channel block intervals prior to the reverse channel transmission by the identified specific subscriber device 26. Furthermore, the Reservation Identifier flag is reset two blocks prior to the termination of the reverse channel transmission by the identified subscriber device 26. The identifier may be reset to indicate the identification of the next subscriber device 26 for which the reverse channel has been allocated or reset to the null identifier depending upon which operating mode is utilized by base station 24.

20

For the purposes of these procedures, base station 24 maintains a counter that increments as each forward channel block is encoded and transmitted. A typical scenario is illustrated in FIG. 17. Base station 24 sets the Reservation Identifier that is encoded and transmitted in the N^{th} forward channel block according to the following rules:

25

IF A reservation request was received on the reverse channel and granted while the $(N-2)^{\text{nd}}$ block was transmitted on the forward channel
 THEN Base station 24 sets the Reservation Identifier to the reservation identifier of the specific subscriber device 26 for which the reverse channel will be allocated.

35 IF Base station 24 determines that a reserved transmission by subscriber device 26 will terminate during the $(N + 1)^{\text{th}}$ forward channel block interval
 THEN Base station 24 examines the reservation queue

-35-

IF Base station 24 determines that one or more reservation requests are still outstanding
 THEN Base station 24 resets the Reservation Identifier to the reservation identifier of the next
 subscriber for which the reverse channel will be allocated
 ELSE Base station 24 resets the Reservation Identifier to the null value

5

IF A reservation request was received on the reverse channel and granted while the (N-1)st block
 was transmitted on the forward channel
 THEN Base station 24 sets the Reservation Identifier to the reservation in progress value
 ELSE IF The Reservation / Aloha Flag is set to reservation
 THEN Base station 24 sets the Reservation Identifier to the reservation in progress value
 ELSE Base station 24 sets the Reservation Identifier to the null value

10

Detailed Description of Dynamic Access Control Procedures of the Present Invention

15 An embodiment of dynamic access control methods and apparatus according to the present invention will now be described. As described previously, dynamic access control procedures are beneficial to control channel breakdown and recovery of multiple access channels which are subjected to variable traffic loads to thereby optimize the channel utilization under varying load conditions.

20 The basic Aloha access method allows subscriber device 26 to unconditionally transmit an Aloha access burst in any slot. The dynamic access methods and apparatus of the present invention introduce a Probability of Transmission parameter, Ptx, that eliminates unconditional transmissions. For each transmission attempt, subscriber device 26 generates a random number between

25 0 and 1 (a fair die is preferred)(note that the random number need not be a binary value but may be a selectively large range of values, albeit fractional values, between 0 and 1). If this number is greater than the Ptx parameter that is broadcast in each forward channel block (see FIG. 11) by base station 24, transmission is permitted; otherwise subscriber device 26 does not transmit.

30 Even though a transmission attempt was not made, the subscriber back-off algorithm is executed as if an unsuccessful transmission attempt was actually made. This causes subscriber device 26 to exceed the maximum number of transmission attempts threshold and discard the pending packet for a lower number of actual unsuccessful transmission attempts.

In essence, as the attempted traffic rate rises, the dynamic access methods and apparatus of the present invention will adjust the Ptx parameter so that an increasing number of transmission attempts are actually diverted away from the channel so as to maintain the actual channel attempt rate near unity so that optimal channel utilization can be achieved. This allows the channel utilization to be maintained during transients when the attempt rate due to new arrivals and the re-transmission of previously failed packets exceeds unity, or in situations when the arrival of new packets sustains a rate which is too high to be supported by the channel. This latter scenario is typical, for example, of the one-way paging busy hour just prior to noon in a radio based messaging and paging service environment. Using the methods and apparatus of the present invention, even in cells which are over-subscribed the channel will not lose revenue due to loss of channel utilization. Furthermore, in one embodiment, base station 24 reports the Ptx parameter to the Network Management system or controller 22 on a regular basis so the system provider may identify when cells are becoming capacity limited and where new cells should be provided.

Prior to a transmission attempt, controller 24 preferably selects a cell that enables the highest probability that a transmission will occur, that is the least busy cell, for the transmission. Furthermore, subscriber device 26 may elect to conserve battery power by not even attempting a transmission where the Probability of Transmission parameter indicates that a transmission attempt may be futile. The transmission attempt may be postponed to a later time when the channel is less busy.

The numerical precision of the Ptx parameter defines the accuracy to which the channel utilization can be controlled. High numerical precision theoretically would allow an Aloha channel utilization to be held at a perfect 36% for any stable attempt rate that exceeds unity. However, because the attempt rate varies as a function of the traffic profile, such precision is not typically warranted. Preferably, a 4-bit Ptx parameter is utilized which is broadcast by base station 24 and that defines a range of uniformly distributed probabilities over the range 0 to 1. Alternatively, for specialized traffic scenarios, the 4 bit index may be utilized to address a lookup table of 16 non-linear quantized Ptx values.

Determination of the 16 values and whether they offer a sufficient control range is dependent upon each application/protocol. However, preferably the selection of each entry should correspond to a range of attempt rates (G) that result in a channel utilization (S) which varies by only a few percentage points.

5 Utilizing a transmission probability parameter Ptx that is an unsigned 4 bit binary integer (ranging 0-15), subscriber devices 26 are permitted to transmit if and only if a subscriber specific 4 bit unsigned random number (generated for each transmission attempt) is less than or equal to the transmission probability, Ptx. Ordinarily, the Ptx parameter is set to 15 indicating that all subscriber
10 Aloha transmission attempts may proceed. However, if the population of subscriber devices 26 that source Aloha attempts increases to a sufficient rate, such that the reverse channel utilization falls below an optimal value, then base station 24 will adjust Ptx to ensure that only a supportable number of transmission attempts are permitted to occur. It is to be understood that the
15 particular range of values used for Ptx is not critical but that the benefits of the present invention may be obtained with any value range in which subscriber device 26 selects one at random and only transmits if the selected number satisfies the broadcast criteria value from base station 24. In addition, specific subscriber devices 26 could be favored or disfavored by providing them a non-
20 random selection of the value for comparison to the broadcast value.

Base station 24 preferably sets Ptx so that a percentage of the Aloha traffic is diverted prior to an actual transmission attempt. This allows base station 24 to maintain the channel utilization during peak traffic periods when the normal subscriber back-off rules are insufficient to prevent an Aloha collapse. This
25 approach provides efficient utilization of the reverse channel but does disadvantage (deny access to) a segment of the subscriber device 26 population. The size of the disadvantaged population increases as Ptx is reduced. A base station 24 that sets Ptx to a value less than 15 for a significant duration of time may be identified as congested.

30 The Dynamic Access Control methods and apparatus of the present invention preferably provide that all subscriber devices 26 attempting to access the reverse channel must utilize the latest, that is most current, value of the

Probability of Transmission parameter, Ptx, that has been estimated and broadcast on the forward channel by base station 24. Referring now to the embodiment illustrated in FIG. 18, the broadcast Ptx value is simply included in the data field of each forward channel Reed Solomon block. Alternatively, the broadcast Ptx value may be included in the channel access status word as illustrated in FIG. 11.

Referring now to FIG. 19, access procedures for subscriber device 26 according to an embodiment of the dynamic access methods and apparatus of the present invention will now be described. If subscriber device 26 has data packets to transmit then it is not permitted to make an unconditional transmission attempt as in a normal Aloha or existing contention based multiple access protocol. Instead, as illustrated at Block 100, subscriber device 26 obtains the latest value of the Probability of Transmission parameter, Ptx, that is broadcast on the forward channel. At Block 102, subscriber device 26 generates a random number which is drawn from the same number space as Ptx. If the random number exceeds the broadcast Ptx value at Block 104, the transmission attempt is permitted at Block 106. Otherwise, the transmission attempt is treated as an unsuccessful transmission attempt. If a packet is transmitted at Block 106 and determined not to have transmitted successfully at Block 108 or if the random number does not exceed the Ptx value at Block 104 an attempt counter is incremented at Block 110 which is used in the back-off method as will be described. This causes an increasing number of transmission attempts to be aborted and packets to be discarded as the Ptx parameter is reduced. Reducing Ptx enables base station 24 to regulate the number of actual reverse channel transmission attempts.

An embodiment of back-off methods suitable for use with the present invention are illustrated further in FIG. 20. As illustrated in FIG. 20, if the attempt count is less than or equal to the maximum retry count, a delay is calculated at Block 114 as a function of the attempt count. Transmission is then delayed for the calculated time as illustrated at Block 116. The packet is then submitted for transmission at Block 118. Preferably, prior to each re-transmission attempt (in the advent of a transmission failure), subscriber device

26 re-acquires the latest Ptx value that is broadcast on the forward channel and furthermore, generates a new random number to determine if the transmission attempt may proceed. If the maximum count is exceeded at Block 112, the packet is discarded (treated as unable to be transmitted) at Block 120.

5 An embodiment of a method for calculating the Ptx value according to the present invention will now be described with reference to FIG. 21. The following terms will be used in the description:

10	Ptx	Transmission Probability, determines the rate of access by a population of subscriber devices 26.
15	Soptimal	Optimal Aloha success rate experienced by base station 24 on the reverse channel (nominally 30%-40%). Soptimal is defined as the rate of successful Aloha bursts received during the Optimal Success Rate Update Window.
20	Scurrent	The current Aloha success rate observed by base station 24 on the reverse channel (variable 0% -50%). Scurrent is defined as the rate of successful Aloha bursts received during the Ptx Adjustment Window.
25	Coptimal	Estimated Aloha collision rate experienced by base station 24 on the reverse channel (nominally 20%-30%) during the same period that Soptimal is computed. Coptimal is defined as the rate of estimated Aloha collisions received during the Optimal Success Rate Update Window.
30	Ccurrent	Estimated Aloha collision rate experienced by base station 24 on the reverse channel (nominally 0%-100%) during the same period that Scurrent is computed. Ccurrent is defined as the rate of estimated Aloha collisions received during the Ptx Adjustment Window.
35	Reduction Factor	Rate of decay for Soptimal, the parameter determines the longevity for which a set of reverse channel conditions and traffic profiles are considered valid.
40	Exponent	Determines the rate at which the Transmission Probability Ptx is updated.
	Margin	Defines a region of acceptable reverse channel utilization in which Ptx should not be adjusted.

Optimal Success

	Rate Update Window	Observation window defined by a specific number of Aloha slots, this window is used to estimate the channel parameters $S_{current}$ and $C_{current}$.
5	Ptx Adjustment Window	Observation window defined by a specific number of Aloha slots. Ptx Adjustment Window < Optimal Success Rate Update Window.
	Avg RSSI	Defined as the average received signal strength indication associated with successful Aloha bursts.
10	Step	Internal algorithm parameter, sets the rate of change of Ptx.

At Block 130, base station 24 monitors the reverse channel to determine successfully received packet and collision rates. The success and collision rates for the reverse channel are calculated at Block 132. Success rate may be determined by counting each block Aloha slot that successfully decodes. The associated reverse channel collision rate is not required to be an absolute estimate but is preferably a consistent estimate. The dynamic access methods and apparatus of the present invention are impervious to collision rate estimates that are constantly under or over estimated, but rely upon the underlying positive gradient monotonic behavior of the collision rate as the attempt rate increases. When utilized in a wireless packet system, the embodiment illustrated in FIG. 21 declares a collision to have occurred when any detection (Aloha) slot exhibits an average RSSI that exceeds the average successful RSSI parameter, yet fails to be successfully decoded. Preferably, base station 24 does not include decoding failures that may be attributed to co-channel interference or local oscillator leakage from subscriber devices 26 located close to base station 24 in determining the collision rate. When utilized in a wireline environment such as a wireless LAN, a collision is simply declared for each slot that fails to decode yet exhibits energy.

An optimal or acceptable success rate is defined for use at Block 134. The acceptable success rate is preferably determined by continually assessing the reverse channel conditions and determining the optimal success rate that can be supported by the reverse channel and the associated collision rate experienced by the reverse channel. In wireless systems, it is preferable that the

system adapts to find the optimal success rate value rather than specifying a fixed theoretical value because the channel conditions may allow additional capacity to be realized through the capture effect or, alternatively, capacity may be lost due to intense co-channel interference from a neighboring system. The reduction factor ensures that long term statistics are not retained which may become obsolete as traffic and cell densities change. A preferred technique for determining the acceptable or optimal success rate for use at Block 134 is as follows:

```

10      compute  $S_{current}$  and  $C_{current}$  by averaging the number of successes and
      collisions over a duration specified by the Optimal Success Rate Update Window
      if      ( $S_{current} > S_{optimal}$ )
      then    $S_{optimal} = S_{current}$ 
            $C_{optimal} = C_{current}$ 
15      else    $S_{optimal} = \max(S_{optimal}, \text{Reduction Factor}, 0.3)$ 

```

The dynamic access methods and apparatus of the present invention assesses the reverse channel conditions and determine the reverse channel utilization. If the utilization of the reverse channel is lower than that offered by the estimated maximum, then the methods and apparatus of the present invention determine if this is due to a high incidence of reverse channel collisions causing an Aloha collapse or if it is simply due to a low attempt rate by the population of subscriber devices 26. In the event of very high reverse channel attempt rates, the probability of transmission parameter, P_{tx} , is reduced. Alternatively, if the attempt rate is low, P_{tx} is kept at a high value to encourage transmission and hence greater utilization of the available reverse channel.

If the success rate is determined not to be acceptable at Block 134, then a change rate or step size for adjusting the value of P_{tx} is determined at Block 136. The step size may be determined as a function of between the optimal and current success rates. For example, the step size may be set to the ratio of the optimal success rate to the current success rate raised to a selected EXPONENT value. However, it is to be understood that a variety of different methods for determining the step size may be beneficially used with the present invention.

If the collision rate is determined to be greater than an optimal or acceptable collision rate at Block 138, the value of Ptx is decreased by the step size from Block 136 at Block 140. Otherwise, the value of Ptx is increased by the step size from Block 136 at Block 142. If the success rate is determined to be acceptable at Block 134, the value of Ptx is not changed. At Block 144, Ptx is broadcast by base station 24 on the forward channel. If Ptx is broadcast as part of a channel control packet as described above, Block 144 corresponds to the broadcast of the channel control packet as illustrated at Block 80 in FIG. 9 (See also FIG. 11 incorporating Ptx in channel access status word). However, it is to be understood that the methods and apparatus of dynamic access control according to the present invention may be beneficially applied in a variety of contention based communications environments and are not limited to the inventive combined contention and reservation mode channel access methods and apparatus described herein. The operations of FIG. 21 may also be described for an embodiment of the present invention as follows:

compute s_{current} and c_{current} by averaging the number of successes and collisions over a duration specified by the Ptx Adjustment Window
 IF $(s_{\text{current}} < s_{\text{optimal}} + \text{Margin})$

$$\text{THEN Step} = \left(\frac{s_{\text{optimal}}}{s_{\text{current}}} \right)^{\text{EXPONENT}}$$

IF $(c_{\text{current}} > c_{\text{optimal}})$
 THEN $\text{Ptx} = \max(\text{min_Ptx}, \text{Ptx} - \text{Step})$
 ELSE $\text{Ptx} = \min(\text{max_Ptx}, \text{Ptx} + \text{Step})$
 ELSE $\text{Ptx} = \text{Ptx}$

While not illustrated in FIG. 21, the MARGIN parameter is utilized to prevent the probability of transmission parameter, Ptx, from dithering about its true value. Packet attempt rates are typically quite variable and fluctuations in the order of a few percentage points are quite normal. Consequently, the estimated collision and success rates will also fluctuate. The MARGIN parameter ensures that the Ptx parameter does not fluctuate. The EXPONENT parameter is utilized to determine the rate of change of the Ptx parameter. These parameters ensure that Ptx can be adjusted rapidly to a significant and

sudden increase in the reverse channel attempt rate such as that which may be encountered just prior to the busy hour in a two-way messaging and paging system.

To summarize, reverse channel Aloha collapse is undesirable because the revenue stream generated by the cell is significantly reduced, subscriber devices burn excess battery power through multiple fruitless transmission attempts and message center originated messages will suffer an inordinate acknowledgment time while subscribers will be prevented from initiating and successfully transmitting a data packet.

The dynamic access methods and apparatus of the present invention have been described herein as applied to a slotted Aloha system solely for the purpose of fully describing the invention. Preferred values for the parameters described above for such an environment are provided in the Table 1 below:

Table 1

Parameter	Initial Value	Value
Soptimal	0.36	
Coptimal	0.26	
Reduction Factor		0.995
Exponent		4
Margin		0.9
Optimal Success Rate Update Window		last 512 Aloha slots
Ptx Adjustment Window		last 128 Aloha slots
Avg RSSI	Determined from cell power product	
Ptx	15	

State Diagram Description of Channel Access Procedures

The basic state machine used by subscriber device 26 to control access to the reverse channel is shown in FIG. 22. Preferably, this procedure should not be violated when a congested forward channel is encountered. Utilization of the Transmission Probability, Ptx, parameter provides system stability during periods in which excess transmission attempts exceed the channel capacity.

If at any time the operation of this state machine is aborted, then all queued data packets are preferably discarded and error messages issued to the Data Link Layer entity indicating that the associated data packets were undeliverable.

5 Furthermore, if the number of transmission attempts in the Aloha Access State (2) exceeds the Max_Tx_Attempts threshold, then the channel stream is declared as congested and the transmission attempt is terminated. A transmission attempt consists of detecting and determining the value of the Reservation/Aloha flag while in the Aloha Access State (2).

10 **IDLE STATE (1)**

 When the MAC layer of subscriber device 26 does not have data packets to transmit, it remains in the idle state (1). In this state the MAC layer entity does not attempt to access the reverse channel. Upon entry into the idle state (1) the MAC layer entity remains in the state for a minimum of Min_Idle_Time forward channel Reed Solomon block intervals. Min_Idle_Time is a system parameter that may be configured.

 The MAC layer entity exits the idle state (1) and enters the aloha access state (2) on receipt of one or more data packets from the Data Link Entity. The MAC layer entity may, by implementation choice, decide to wait for a
20 predetermined number of data packets to be queued or for an implementation specific time to elapse before a transmission is attempted. Furthermore, the subscriber MAC layer is only permitted to add additional data packets to the transmission queue while in the idle state (1).

Prior to exiting from the idle state (1), the subscriber MAC layer shall set a state variable of the No_Tx_Attempts to zero.

ALOHA ACCESS STATE(2)

5 Entry into the aloha access state (2) ordinarily occurs when the Data Link entity has outstanding data packets that require transmission.

Alternatively, the aloha access state(2) can be entered due to an Aloha burst transmission failure or transmission attempt failure.

The subscriber MAC layer, upon receipt of data packets, assesses whether the data packets can be compressed to form a single Aloha
10 transmission burst. Alternatively, the MAC layer will encode the data packets into a sequence of Reservation blocks and construct an Aloha reservation request burst indicating the exact number of reservation blocks for which reverse channel bandwidth should be allocated. Once the subscriber MAC layer has constructed an Aloha burst, it attempts to transmit the burst via the
15 access procedures described herein.

If the state is re-entered due to an Aloha transmission failure or transmission attempt failure then subscriber device 26 delays transmission by implementing the back-off rules described previously. The back-off procedure is utilized to ensure that a repetition of the transmission failure does not occur
20 if the failure was due to a channel collision between two or more subscriber devices attempting to utilize the same Aloha slot. The procedure randomizes subsequent access to the reverse channel.

An embodiment of the procedures governing access by subscriber device 26 will now be provided. For the purposes of these procedures subscriber

device 26 maintains a counter that increments as each forward channel block is received. The procedure is as follows:

```

IF      the subscriber MAC layer has outstanding data packets for transmission
THEN    the subscriber will determine
5      IF      the data packet(s) can be compressed into a single Aloha transmission burst
        THEN    the subscriber device forms a single Aloha transmission burst
        ELSE    the subscriber device encodes the data packet(s) to form a
                sequence of reservation blocks and forms an Aloha reservation
                request specifying the exact number of reservation blocks that are
10      required to be allocated by the base station

```

The subscriber MAC layer then selects at random a forward channel block interval in which the Aloha transmission burst will be transmitted. The forward channel block interval is selected between Min_Count and 2No_Tx_Attempts+1. The delayed block interval does not exceed Max_Count.

15 This block interval is referenced as the Nth forward channel block interval. During the (N-2)nd forward channel block interval the subscriber device shall examine the forward channel Reservation / Aloha flag, determine the transmission probability P_{tx} from the Channel Access Status word and generate a random number uniformly distributed between 0 and 15.

```

20      IF      the Reservation/Aloha flag indicates Aloha and the subscriber MAC layer has a queued Aloha
                transmission burst and the random number is less than the transmission probability Ptx
        THEN    the subscriber device transmits in one of the three available Aloha slots (selected at random) during the
                Nth forward channel block interval, increments the No_Tx_Attempts state variable and enters the
                decode wait state (3)
25      ELSE IF the Reservation/Aloha flag indicates Aloha and the subscriber MAC layer has a queued Aloha
                reservation request and the random number is less than the transmission probability Ptx
        THEN    the subscriber device transmits in one of the three available Aloha slots (selected at random)
                during the Nth forward channel block interval, increments the No_Tx_Attempts state variable
                and enters the reservation wait state (4)

```

ELSE IF the No_Tx_Attempts exceeds Max_Tx_Attempts
 THEN the subscriber device discards all outstanding data packet(s), issues an error message to the Data Link entity indicating that the outstanding data packets were undeliverable and enters the idle state (1)

5 ELSE IF the entrance delay exceeds Max_Entrance_Delay
 THEN the subscriber device discards all outstanding data packet(s), issues an error message to the Data Link entity indicating that the outstanding data packets were undeliverable and enters the idle state (1)

ELSE the subscriber device aborts the transmission attempt, increment the No_Tx_Attempts state variable and re-enters the aloha access state (2)

10

DECODE WAIT STATE (3)

When the subscriber MAC layer entity is in the decode wait state(3) it attempts to determine the success of the previous Aloha transmission. For the purposes of these procedures subscriber device 26 maintains a counter that increments as each forward channel block is received. Subscriber device 26 examines the Decode Status that is encoded and transmitted in the Nth forward channel block and execute the following procedures.

IF the subscriber device transmitted an Aloha burst in one of three available Aloha slots in the (N-2)nd forward channel block interval

20 THEN the subscriber device examines the corresponding decode status bit in the channel access status word embedded in the Nth forward channel block

IF the decode status indicates that the subscriber Aloha transmission was successful

THEN the subscriber device enters the idle state (1)

25 ELSE IF the decode status indicates that the subscriber Aloha transmission was unsuccessful

THEN the subscriber device enters the aloha access state (2)

ELSE IF the forward channel block cannot be decoded due to an impaired block

30 THEN the subscriber device examines the corresponding decode status bit in the channel access status word embedded in the (N + 1)st forward channel block

-48-

IF the decode status indicates that the subscriber Aloha transmission was successful
 THEN the subscriber device enters the idle state (1)

ELSE IF the decode status indicates that the subscriber Aloha transmission was unsuccessful
 5 THEN the subscriber device enters the aloha access state (2)

ELSE the decode status is indeterminate due to two concurrent forward channel block errors
 THEN the subscriber device issues an error message to the Data link layer indicating that a potentially
 unsuccessful transmission of the data packets has occurred and enters the idle state (1)

10

RESERVATION WAIT STATE (4)

When the subscriber MAC layer entity is in the reservation wait state(3) it
 attempts to determine the success of the previous Aloha reservation request
 transmission burst. For the purposes of these procedures subscriber device 26
 15 maintains a counter that increments as each forward channel block is received.
 Subscriber device 26 examines the Reservation/ Aloha Flag, Reservation
 Identifier and Decode Status that is encoded and transmitted in the Nth forward
 channel Reed Solomon block and execute the following procedures.

IF the subscriber device transmitted an Aloha reservation request in one of three available Aloha slots in
 20 the (N-2)nd forward channel block interval

THEN the subscriber device examines the Reservation / Aloha flag and the Reservation Identifier in the Nth
 forward channel block

IF the subscriber device determines that the Reservation / Aloha flag is set to reservation and the
 25 Reservation Identifier matches the device reservation identifier

THEN the subscriber device enters the transmit reservation access state (5)

ELSE IF the system is operating in Mode 1 or Mode 2.

THEN the subscriber device enters the aloha access state (2).

30

ELSE the system is operating in Mode 0 or Mode 3 and the subscriber device examines the corresponding decode status bit in the channel access status word embedded in the Nth forward channel block.

IF the forward channel block cannot be decoded due to an impaired block

5 THEN the subscriber device examines the decode status bits in the channel access status word embedded in the (N+1)st forward channel block

IF the decode status indicates that the subscriber Aloha transmission was successful

THEN the subscriber device examines the Reservation/Aloha flag and Reservation Identifier in each subsequent forward channel block.

10 IF the subscriber device determines that the Reservation/Aloha flag is set to reservation and the Reservation Identifier matches the device reservation identifier

THEN the subscriber device enters the transmit reservation access state (5)

15 ELSE IF the subscriber device determines that the Reservation/Aloha flag is set to indicate Aloha access and the Reservation Identifier is set to the null value

THEN the subscriber device enters the aloha access state (2)

20 ELSE the decode status indicates that the subscriber Aloha transmission was unsuccessful and the subscriber device enters the aloha access state (2).

TRANSMIT RESERVATION ACCESS STATE (5)

Upon initial entry into the transmit reservation access state (5), the

25 subscriber MAC layer entity waits for two forward channel block durations prior to transmission. During transmission, the subscriber MAC layer entity does not add additional data packets to the transmission queue. When all data packets have been transmitted, the subscriber MAC layer entity enters the idle state(1). For the purposes of these procedures, subscriber device 26 maintains a

counter than increments as each forward channel block is received. The procedures governing this procedure are detailed below.

- 5 IF the subscriber device determined that the Reservation Identifier in the N^{th} forward channel block matched the subscriber reservation identifier
- THEN the subscriber device transmits a contiguous set of blocks; the first block will be transmitted during the $(N-2)^{\text{nd}}$ forward channel block interval. The number of transmitted blocks is identical to the number of blocks requested in the Aloha reservation request transmission. The transmitted reservation blocks contain the data packets.
- 10 IF the subscriber device has completed transmission of the reservation blocks
- THEN the subscriber device enters the idle state(1).

The basic state machine used by base station 24 for controlling access to the reverse channel by the population of subscriber devices 26 is illustrated in the state diagram of FIG. 23. The setting of the Reservation/Aloha flags and the Reservation Identifier occurs at the correct block boundaries.

CHANNEL IDLE STATE (1)

Initially, base station 24 sets the Reservation/Aloha flag to indicate that Aloha transmission bursts may be received, sets the Reservation Identifier to the null value, and enters the channel idle state (1). Base station 24 remains in the channel idle state (1) until a forward channel block boundary is reached:

- 25 IF the base station determines that one or more reservation requests are queued for pending service and that the Reservation/Aloha flag has been set to reservation for the previous two forward channel Reed Solomon blocks
- THEN the base station enters the receive reservation blocks state (4)
- else the base station enters the receive aloha bursts state (3)

RECEIVE ALOHA BURSTS STATE (2)

Base station **24** remains in the receive aloha bursts state (3) for the duration of the forward channel block period. During this time interval, base station **24** examines in turn each of the three reverse channel Aloha slots for the existence
 5 of an Aloha burst from a subscriber device **26**. For each Aloha slot, base station **24** attempts to demodulate and detect an Aloha burst.

IF an Aloha burst is received error free or is successfully corrected
 THEN the base station sets the corresponding decode status bits to indicate success

10 The base station **24** examines all received and correctly decoded Aloha bursts for a MAC layer reservation request or a data packet. Reservation requests and the associated subscriber reservation identifications will be stored. Base station **24** remains in the receive aloha bursts state (3) until all three Aloha slots have been examined for the existence of a subscriber device **26** originated
 15 transmission:

IF the base station has examined all three Aloha slots and one or more reservation requests have been received
 THEN the base station enters the reservation grant state (3)
 ELSE the base station returns to the channel idle state (1)

20

RESERVATION GRANT STATE (3)

While in the reservation grant state (3) base station **24** examines the list of reservation requests:

IF the base station is currently operating in Mode 0
 25 THEN the base station executes system specific procedures
 ELSE IF the base station is operating in Mode 1 (Aloha only)

THEN the base station ignores the reservation request and sets the corresponding decode status bits to failure

5 ELSE IF the base station is operating in Mode 2 (Aloha and Serve One Reservation at Random)
THEN the base station examines the reservation queue

IF one reservation request is already pending service and the base station has previously acknowledged the request

10 THEN the base station discards all reservation requests received in the previous three Aloha slots and sets the corresponding decode status bits for each received reservation request to failure

ELSE the base station selects from the remaining reservation requests one reservation identifier at random

15 Sets the forward channel Reservation Identifier to match the chosen subscriber and the Reservation/Aloha flag to reservation

Sets the corresponding decode status bits associated with the selected reservation request to success

20 Sets the decode status bits for each received reservation request that is not selected to failure

ELSE IF the base station is operating in Mode 3 (Aloha and Queued Reservations)
THEN the base station appends the reservation request(s) to the reservation queue

25 Sets the decode status bits associated with each reservation request to success

Sorts the reservation queue so that reservation requests for shorter reverse channel transmissions are served in preference to longer reservation requests

30 Sets the forward channel Reservation Identifier to match the first subscriber in the reservation queue and the Reservation/Aloha flag to reservation

On completion of the above procedures the base station enters the channel idle state (1)

RECEIVE RESERVATION BLOCKS STATE (4)

While in the receive reservation blocks state (4) base station 24 attempts to detect and synchronize to the reverse channel subscriber device 26 transmission of reservation blocks. The transmission from subscriber device 26, if present, includes an embedded synchronization sequence that is present in each of a predetermined number of reservation blocks. The number of blocks will be identical to that requested in the initial reservation request and allocated by base station 24.

IF the base station acquires synchronization with a reverse channel transmission

10 THEN the base station attempts to decode a reservation block for each allocated block that has been reserved

Procedures for Mode 2 (Aloha and Serve One Reservation at Random)**15 Operation.**

IF the base station is operating in Mode 2 and has successfully acquired synchronization with the subscriber transmission

20 THEN two blocks prior to the completion of the subscriber transmission the base station sets the Reservation/Aloha flag to Aloha and sets the Reservation Identifier to the null value

On completion of the subscriber transmission the base station enters the channel idle state (1).

25

Procedures for Modes 1 and 3 (Aloha and Queued Reservations) Operation.

IF the base station is operating in Mode 3 and has successfully acquired synchronization with the subscriber transmission

THEN two blocks prior to the completion of the subscriber transmission the base station re-examines the reservation queue

5 IF the reservation queue is empty

THEN the base station sets the Reservation/Aloha flag to Aloha and sets the Reservation Identifier to the null value

10 On completion of the subscriber transmission the base station enters the channel idle state (1).

ELSE the base station sets the Reservation Identifier to the identification value of the next subscriber device in the reservation queue and remains in the receive reservation blocks state (4)

15 IF the base station is operating in Mode 3 and determines in an implementation dependent manner that the subscriber transmission is absent

THEN the base station maintains the Reservation/Aloha flag indicating reservation, sets the Reservation Identifier to the identification value of the next subscriber device in the reservation queue and remains

20 in the receive reservation blocks state (4)

System Stability

The benefits of the present invention may further be understood in the context of Aloha system performance. The dynamics of the stability issue may be revealed if the throughput versus attempt rate response (S vs. G curve) of an existing slotted

25 Aloha system is considered, as illustrated in FIG. 24. Misinterpretation of the system's performance occurs because it would appear that provided the attempt rate (G) is kept below unity, the channel utilization (S) would appear acceptable and stable. Unfortunately this static interpretation is flawed because it does not reflect the time based dynamic behavior of the system. The Aloha system is stable

if and only if the departure rate is equal to the arrival rate. Consider the scenario when the attempt rate is unity. For every 10 transmission attempts, approximately 3 are successful. The 7 unsuccessful packets will become queued for re-transmission. During a subsequent time interval in which another 10 transmission attempts are executed, only 3 transmission attempts may correspond to new packets that have arrived if stability is to be achieved. If less than 3 new packets arrive, the operating point on the Aloha response curve will drift to the left and the channel utilization will fall. This is a satisfactory occurrence because although the channel is not being utilized at its maximum, the delay experienced with the delivery of each packet is negligible and the system appears to provide excellent service to all users. However, if the number of new arrivals exceeds 3, the number of transmission attempts in a subsequent interval of time will exceed 10 and, as a consequence, an increase in the number of collisions will be observed. This will cause the number of successful transmissions to fall, which results in a decrease in channel utilization and a further increase in the number of attempted re-transmissions during a subsequent time slot. Consequently, the operating point drifts to the right of the optimum operating point. If the new arrival rate continues to exceed the successful departure rate then the operating point will continue to drift to the right. This is a highly undesirable scenario because the channel utilization falls and, as a consequence, so does the level of revenue-bearing traffic. The delay associated with the delivery of each packet dramatically increases and the quality of the system that is perceived by the users falls. This scenario is often referred to as an Aloha or Reverse channel collapse.

To prevent Aloha instability, a subscriber device is only permitted to re-transmit each packet a finite number of times. Furthermore, each re-transmission is required to be delayed by an exponentially increased delay. It is important to realize that this back off policy does not eliminate the possibility that system instability can occur; rather the possibility is significantly reduced. Furthermore, if the channel utilization does fall because the attempt rate has exceeded the maximum that the system can support, then the back off policy provides a mechanism for recovery if instability occurs. The stability issue is normally addressed by providing back off rules, such as:

10 IF a transmission attempt fails

 THEN the subscriber device will delay a subsequent transmission
 attempt by a random time interval

 IF the number of transmission attempts exceeds a predetermined
 threshold

15 THEN the subscriber device will discard the queued packet and abort the
 transmission attempt

The first rule minimizes the possibility that two or more subscriber devices will execute re-transmission attempts after an initial collision in an identical time slot. This approach provides an effective splitting algorithm that prevents continuous repeating collisions but it does not reduce the actual attempted traffic. The second rule provides a form of non-persistence which allows the system to recover and the operating point to actually drift left towards the desirable operating region. The rule effectively increases the departure rate, and departures are now partitioned between those that are successfully transmitted and those that

are abandoned. The non-persistence rule introduces a change in the system behavior. Referring now to **FIG. 24**, if the system is operating at the optimum operating point and the successful departure rate is matched by the attempted traffic of both new arrivals and re-transmissions, then the operating point will remain at this position. If a transient increase in the attempted traffic rate occurs, then the operating point will drift to the right and the channel utilization will fall. If the rate of new arrivals decays to the original rate, the non-persistence rule will slowly flush the excess packets queued for transmission and the operating point will recover and drift left towards the optimum operating point.

The above stabilization procedure is typically only viable in systems where the contribution to the attempted traffic from new arrivals is essentially steady, predictable and sufficiently low so that the total attempted traffic rate can remain at or below unity. The technique can control short term transient increases in the arrival rate, which are assumed to be infrequent, and the associated loss in channel utilization can be tolerated. **FIG. 25** illustrates a scenario in which this stabilization technique fails. If the number of new arrivals exceeds the departure rate (both successful and aborted) then the operating point will continue to drift to the right. This scenario could quite easily occur for a two-way paging and messaging system utilizing Aloha during the busy hour (just prior to lunch) in an over subscribed downtown cell. Despite the fact that the channel is incapable of supporting the traffic volume, it would be desirable for the channel to be utilized effectively by a subset of the subscriber population so that the service provider could still generate a revenue-bearing traffic stream. This capability is provided by the dynamic access methods and apparatus of the present invention.

In the drawings and specification, there have been disclosed typical preferred embodiments of the invention and, although specific terms are employed, they are used in a generic and descriptive sense only and not for purposes of limitation, the scope of the invention being set forth in the following claims.

THAT WHICH IS CLAIMED:

1. A channel access method for communicating a data packet over a multiple access communication network having a forward channel and a reverse channel comprising the steps of:

periodically broadcasting a channel control packet on the forward channel;

5 receiving one of the broadcast channel control packets;

reading the received channel control packet to determine if a contention or reservation mode is indicated;

determining if the data packet to be communicated exceeds a predetermined size;

10 transmitting the data packet on the reverse channel if contention mode is indicated in said reading step and if the data packet size is no larger than the predetermined size in said determining step;

transmitting a reservation request on the reverse channel if contention mode is indicated in said reading step and if the data packet size exceeds the predetermined size in said determining step; and, then,

15 receiving a second one of the broadcast channel control packets;

reading the received second one of the broadcast channel control packets to determine if reservation mode is indicated; and,

20 transmitting the data packet on the reverse channel if reservation mode is indicated in said step of reading the received second one of the broadcast channel control packets.

2. The channel access method of Claim 1 wherein the following steps are performed following said step of transmitting a reservation request on the reverse channel:

receiving the transmitted reservation request; and,

5 broadcasting a channel control packet on the forward channel responsive to the received transmitted reservation request indicating reservation mode.

3. The channel access method of Claim 2 wherein the reservation request includes an identifier associated with a device transmitting a reservation request and wherein the following steps are performed after said step of receiving the transmitted reservation request:

5 reading the reservation request to determine the identifier associated with the device transmitting the reservation request; and,

determining if reservation mode access to the reverse channel is available to the device transmitting the reservation request; and

10 wherein said step of broadcasting a channel control packet on the forward channel responsive to the received transmitted reservation request includes the step of broadcasting a channel control packet indicating reservation mode and including an access device identifier associated with the device transmitting the reservation request if it is determined that reservation mode access is available in said determining if reservation mode access to the reverse channel is available step;

15 and,

wherein said step of reading the received second one of the broadcast channel control packets to determine if reservation mode is indicated includes the step of reading the access device identifier; and,

20 wherein said step of transmitting the data packet on the reverse channel if reservation mode is indicated includes the step of transmitting the data packet only if the received access device identifier identifies the device attempting to transmit the data packet.

4. The channel access method of Claim 3 wherein the reservation request further includes an indication of the size of the data packet to be transmitted.

5 5. The channel access method of Claim 2 wherein the forward channel is delineated into forward channel blocks and wherein reverse channel transmissions are synchronized to correspond to forward channel blocks and wherein said step of periodically broadcasting the channel control packet includes the step of broadcasting a channel control packet in each of the forward channel blocks.

6. The channel access method of Claim 5 wherein the following step is performed following said step of reading the received channel control packet to determine if a contention or reservation mode is indicated:

5 selecting one of a predetermined number of contention mode transmission windows corresponding to portions of the forward channel block designated for contention mode transmission; and



10. The channel access method of Claim 5 wherein the channel control packet further includes an acknowledgment status flag associated with a preceding one of the forward channel blocks indicating whether a transmission was received.

11. The channel access method of Claim 10 wherein said step of reading the received channel control packet to determine if a contention or reservation mode is indicated includes the step of reading the acknowledgment status flag of the received channel control packet to determine if a previous transmission was received and wherein the following step is performed following said step of reading the received channel control packet:

submitting for retransmission a preceding transmission if the acknowledgment status flag of the received channel control packet indicates that the preceding transmission was not received.

12. The channel access method of Claim 3 wherein said step of receiving the transmitted reservation request includes the step of receiving a plurality of transmitted reservation requests and wherein said step of determining if reservation mode access to the reverse channel is available includes the step of queuing the plurality of received transmitted reservation requests for reservation mode access to the reverse channel.

13. The channel access method of Claim 3 wherein the channel control packet further includes an acknowledgment status flag associated with a previously transmitted data packet indicating whether the data packet was received.

14. The channel access method of Claim 13 wherein said step of reading the received channel control packet to determine if a contention or reservation mode is indicated includes the step of reading the acknowledgment status flag of the received channel control packet to determine if a previously transmitted data packet was received and wherein the following step is performed following said step of reading the received channel control packet:

submitting for retransmission a previously transmitted data packet if the acknowledgment status flag of the received channel control packet indicates that the previously transmitted data packet was not received.

15. The channel access method of Claim 1 wherein the multiple access communication network is a wireless network.

16. The channel access method of Claim 15 wherein the wireless network is a cellular network.

17. The channel access method of Claim 1 wherein the following steps are performed following said reading step:

determining if the received packets were received without error; and

generating a dynamic access control parameter for regulating access to the reverse channel based on whether the received packets were received without error; and

wherein said step of periodically broadcasting a channel control packet includes the step of periodically broadcasting a channel control packet including the generated dynamic access control parameter.

18. The channel access method of Claim 17 wherein the following steps are performed following said reading step:

reading the dynamic access control parameter in the received channel control packet;

5 generating an access control limit value; and

submitting a packet for transmission if the generated access control limit value satisfies the dynamic access control parameter.

19. The channel access method of Claim 1 wherein said reading step includes the step of reading the received channel control packet to determine a reverse channel operation mode.

20. A forward channel transmission apparatus for use in a multiple access communication network having a forward channel and a multiple access reverse channel, the apparatus comprising:

5 broadcasting means operatively connected to said forward channel for broadcasting a channel control packet on said forward channel, said channel control packet including an indication of reservation or contention mode and an identifier;

receiving means operatively connected to said reverse channel for receiving a data packet on said reverse channel and for receiving a reservation request including an identifier associated with the requesting device on said reverse channel;

reading means responsive to said receiving means for reading said reservation request to determine said identifier associated with said requesting device;

determining means responsive to said reading means for determining if reservation mode access to said reverse channel is available to said requesting device and for determining if reservation mode or contention mode will be selected for said reverse channel; and,

generating means responsive to said determining means for generating said channel control packet including setting said reservation or contention mode indication and said identifier.

21. The forward channel transmission apparatus of Claim 20 wherein said determining means further comprises means for determining if said data packet or said reservation request have been successfully received and wherein said channel control packet further includes an acknowledgment of successfully received data packets or reservation requests and wherein said generating means further includes means for setting said acknowledgment of successfully received data packets or reservation requests.

22. The forward channel transmission apparatus of Claim 20 further comprising means for queuing a plurality of said reservation requests.

23. The forward channel transmission apparatus of Claim 20 wherein said forward channel is delineated into forward channel blocks and wherein said broadcasting means includes means for broadcasting one of said channel control packets in each of said forward channel blocks and wherein transmissions on said reverse channel are synchronized to correspond to said forward channel blocks and wherein said generating means further includes means for generating and providing to said broadcasting means one of said channel control packets including an indication of reservation or contention mode and an identifier associated with a subsequent one of said forward channel blocks.

24. The forward channel transmission apparatus of Claim 20 wherein said multiple access communication network is a wireless network.

25. The forward channel transmission apparatus of Claim 20 wherein said wireless network is a cellular network.

26. A reverse channel transmission apparatus for use in a multiple access communication network having a forward channel and a multiple access reverse channel, the apparatus comprising:

receiving means for receiving a channel control packet on said forward channel;

reading means operatively connected to said receiving means for reading said received channel control packet to determine if a contention or a reservation mode

is indicated and if an identifier associated with said reverse channel transmission apparatus is included in said channel control packet;

10 determining means for determining if a data packet to be communicated exceeds a predetermined size;

means responsive to said reading means and said determining means for transmitting said data packet on said reverse channel if contention mode is indicated and if said data packet is no larger than said predetermined size and for
15 transmitting said data packet on said reverse channel if reservation mode is indicated and if an identifier associated with said reverse channel transmission apparatus is included in said channel control packet; and,

means responsive to said reading means and said determining means for transmitting a reservation request on said reverse channel if contention mode is
20 indicated and if the size of said data packet exceeds said predetermined size.

27. The reverse channel transmission apparatus of Claim 26 wherein said means for reading said received channel control packet includes means for reading an acknowledgment status flag in said channel control packet to determine if a previously transmitted data packet was received and wherein said reverse channel
5 transmission apparatus further comprises:

means responsive to said reading means for submitting for retransmission said previously transmitted data packet if said previously transmitted data packet was not received.

28. The reverse channel transmission apparatus of Claim 26 wherein said forward channel is delineated into forward channel blocks and wherein transmissions by said means for transmitting data packets and said means for transmitting reservation requests are synchronized to correspond to said forward channel blocks and wherein said means for transmitting data packets and said means for transmitting reservation requests transmit in a selected subsequent one of said forward channel blocks associated with said received channel control packet.

29. The reverse channel transmission apparatus of Claim 26 wherein said multiple access communication network is a wireless network.

30. The reverse channel transmission apparatus of Claim 29 wherein said wireless network is a cellular network.

FIG. 1

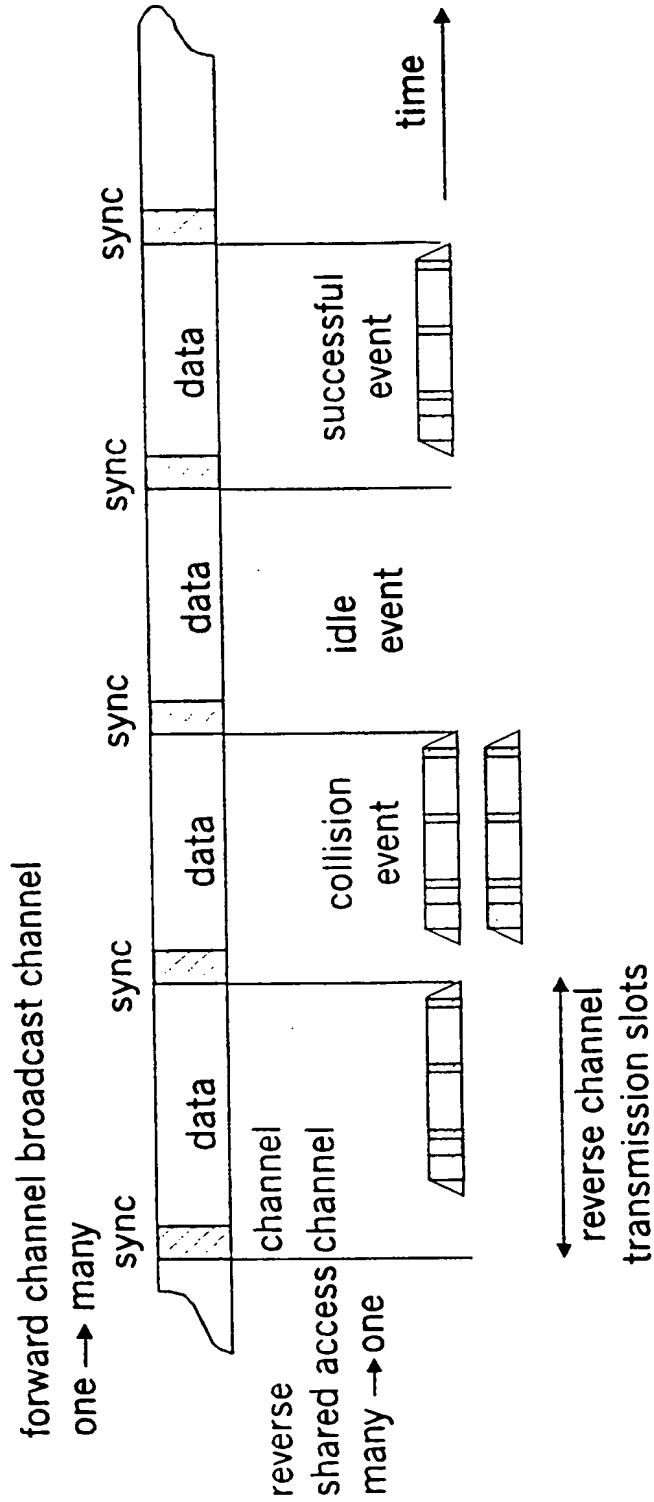

FIG. 2

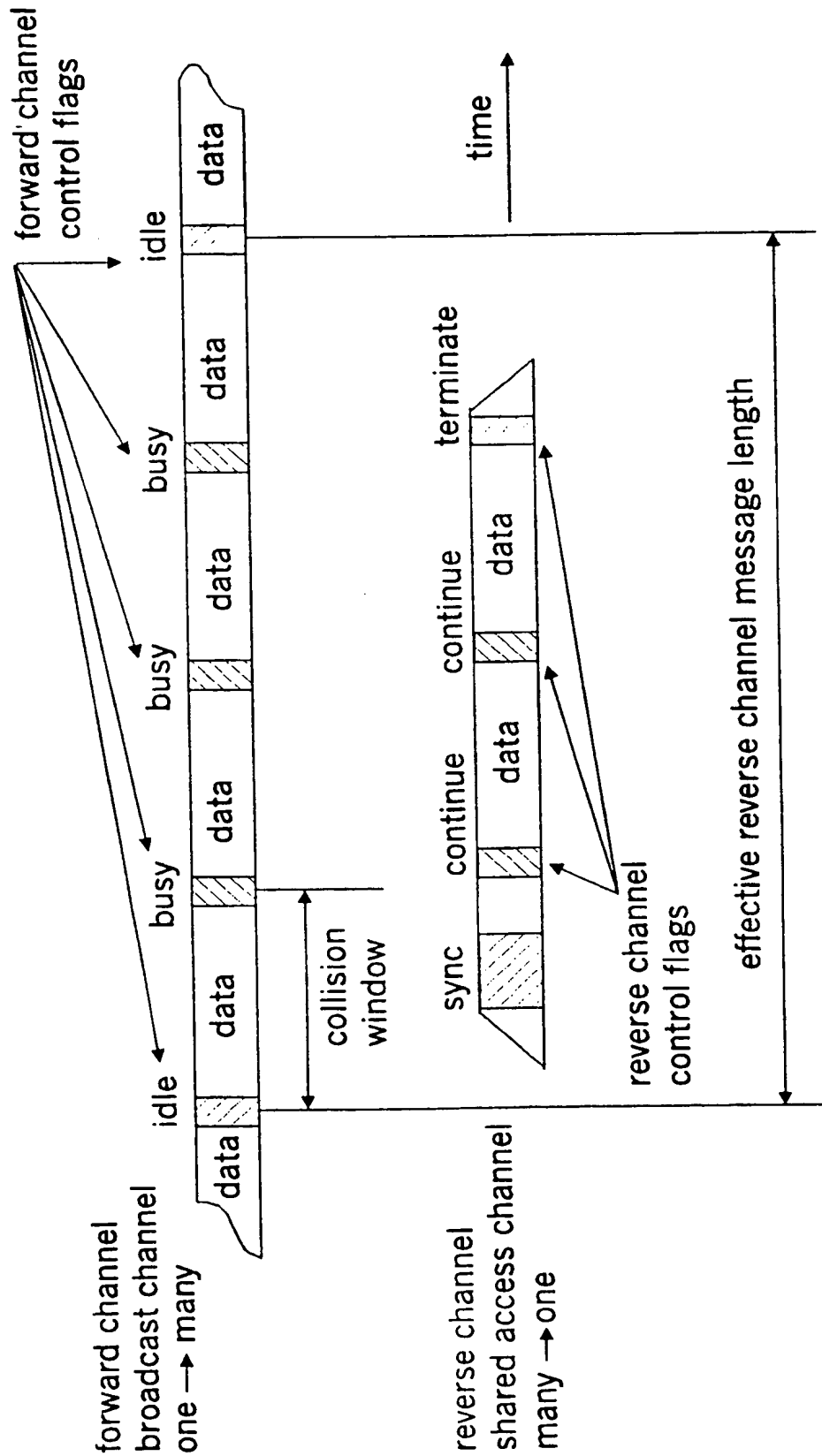

FIG. 3

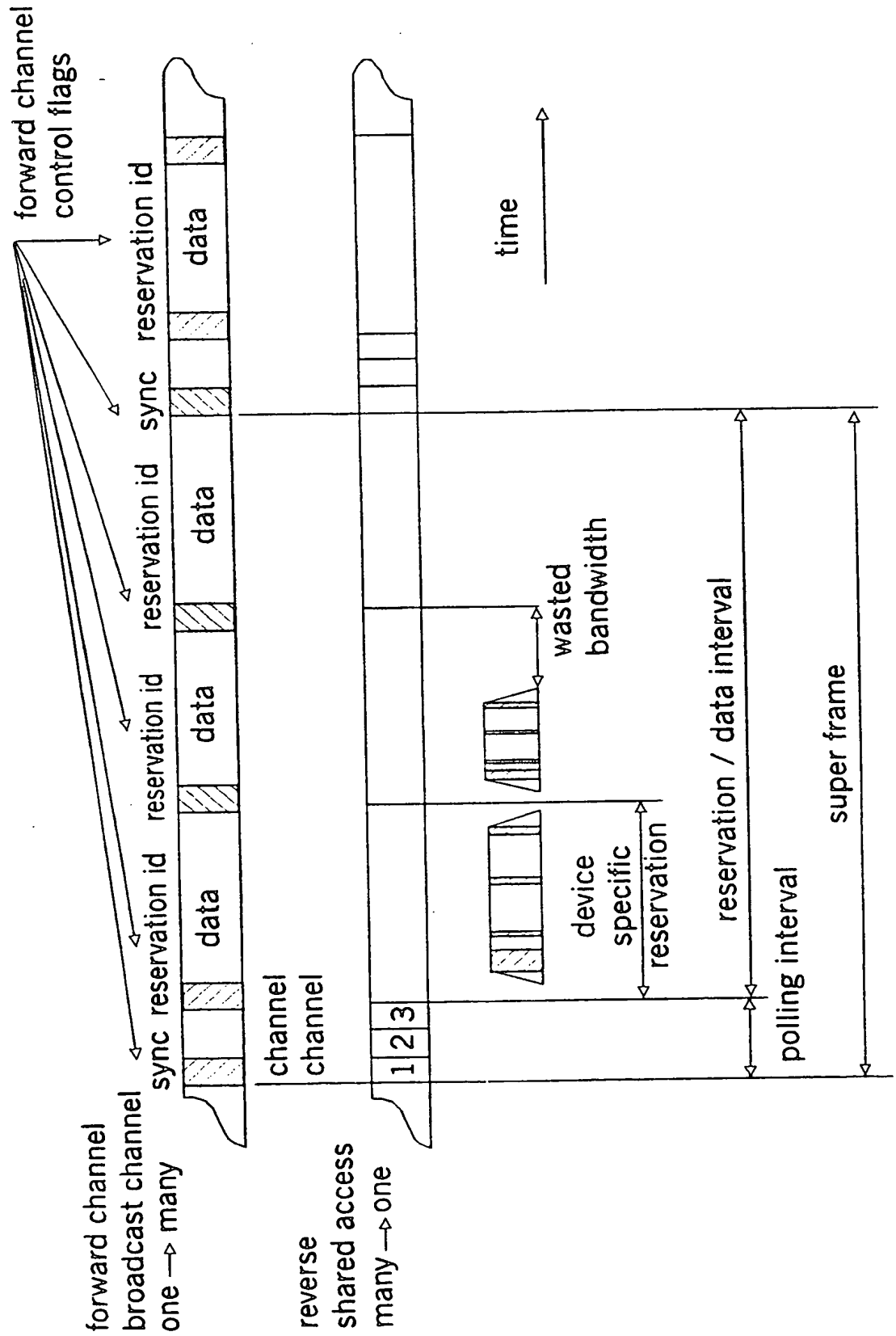
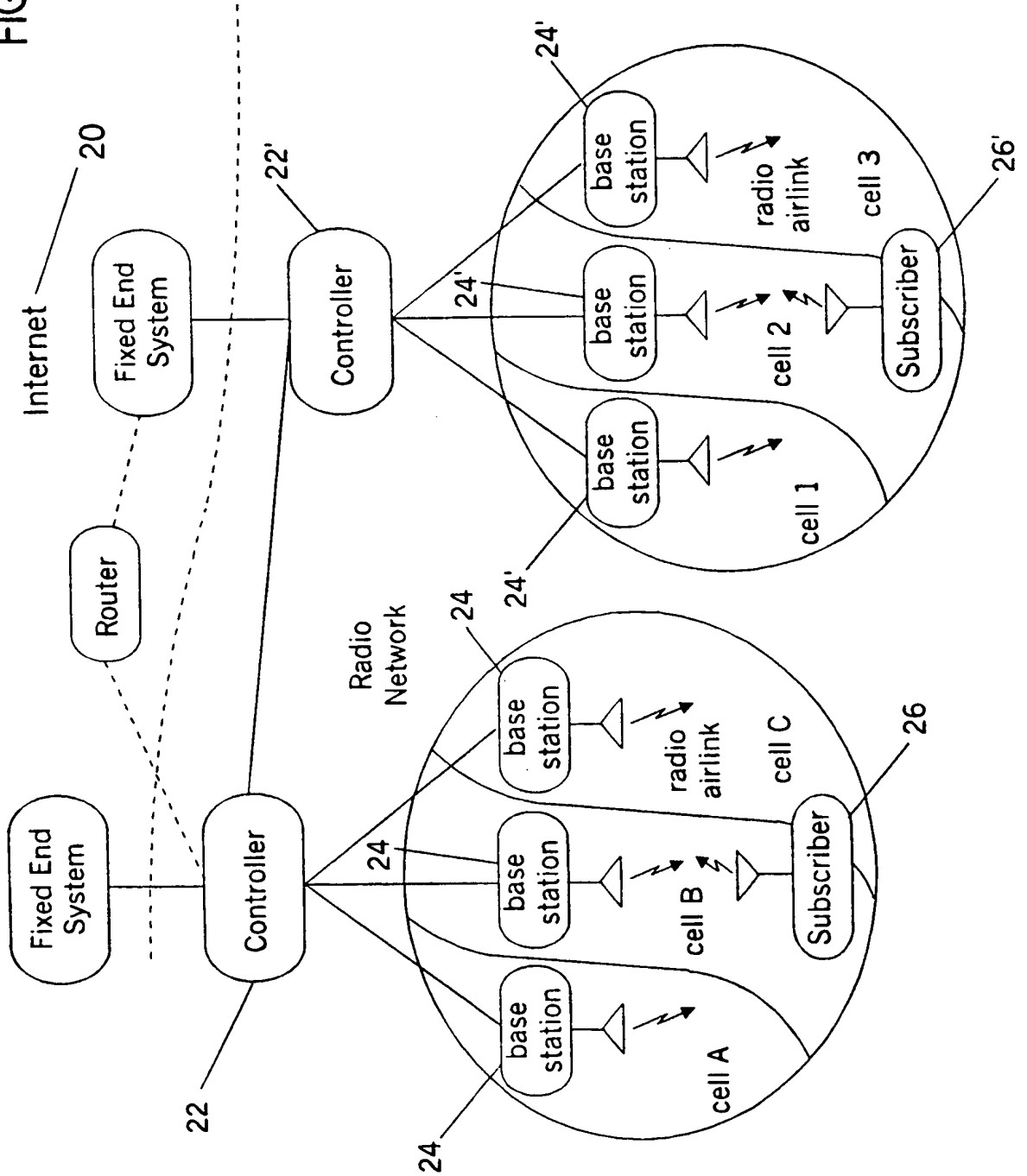

FIG. 4



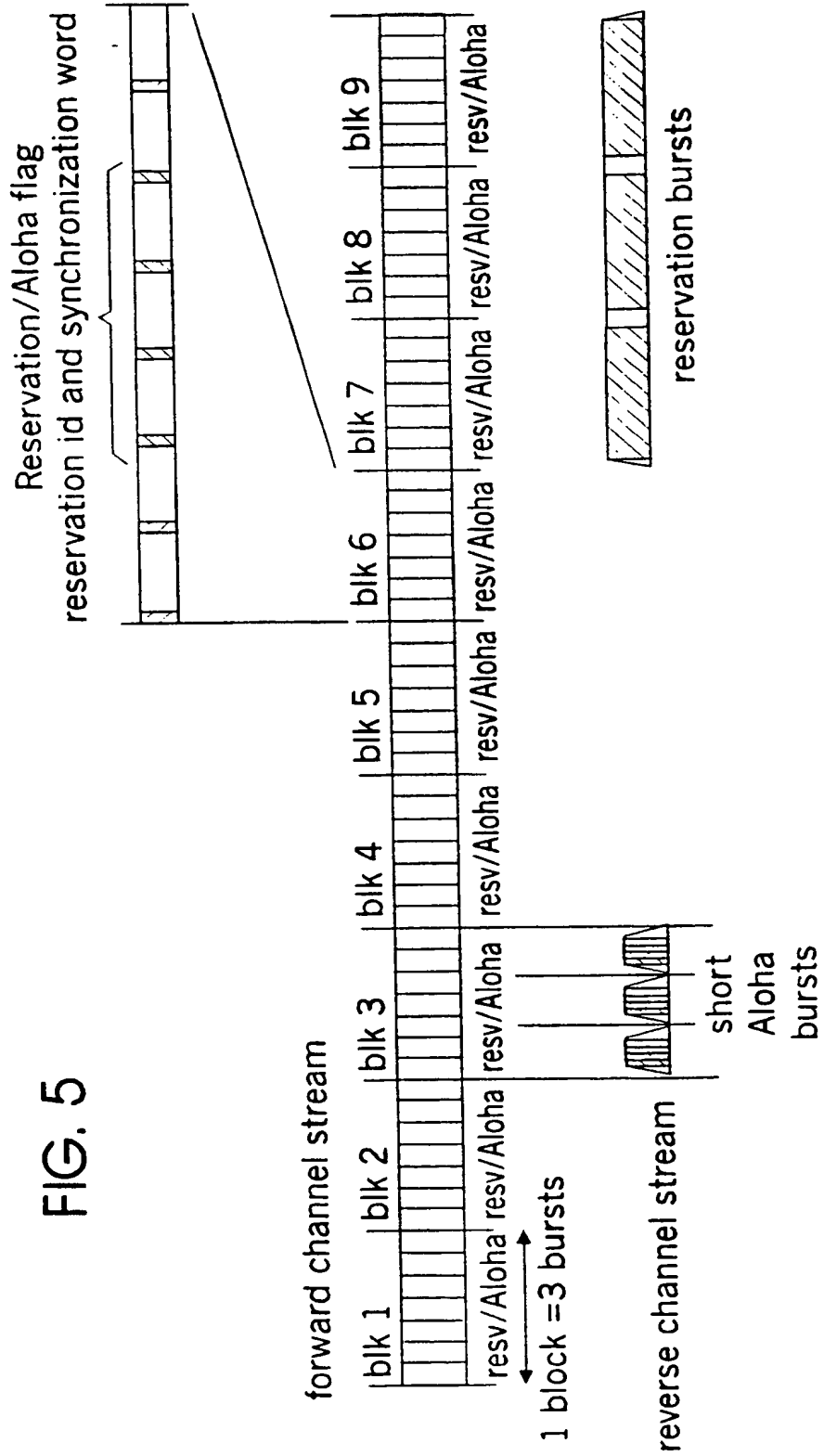

FIG. 5

FIG. 6

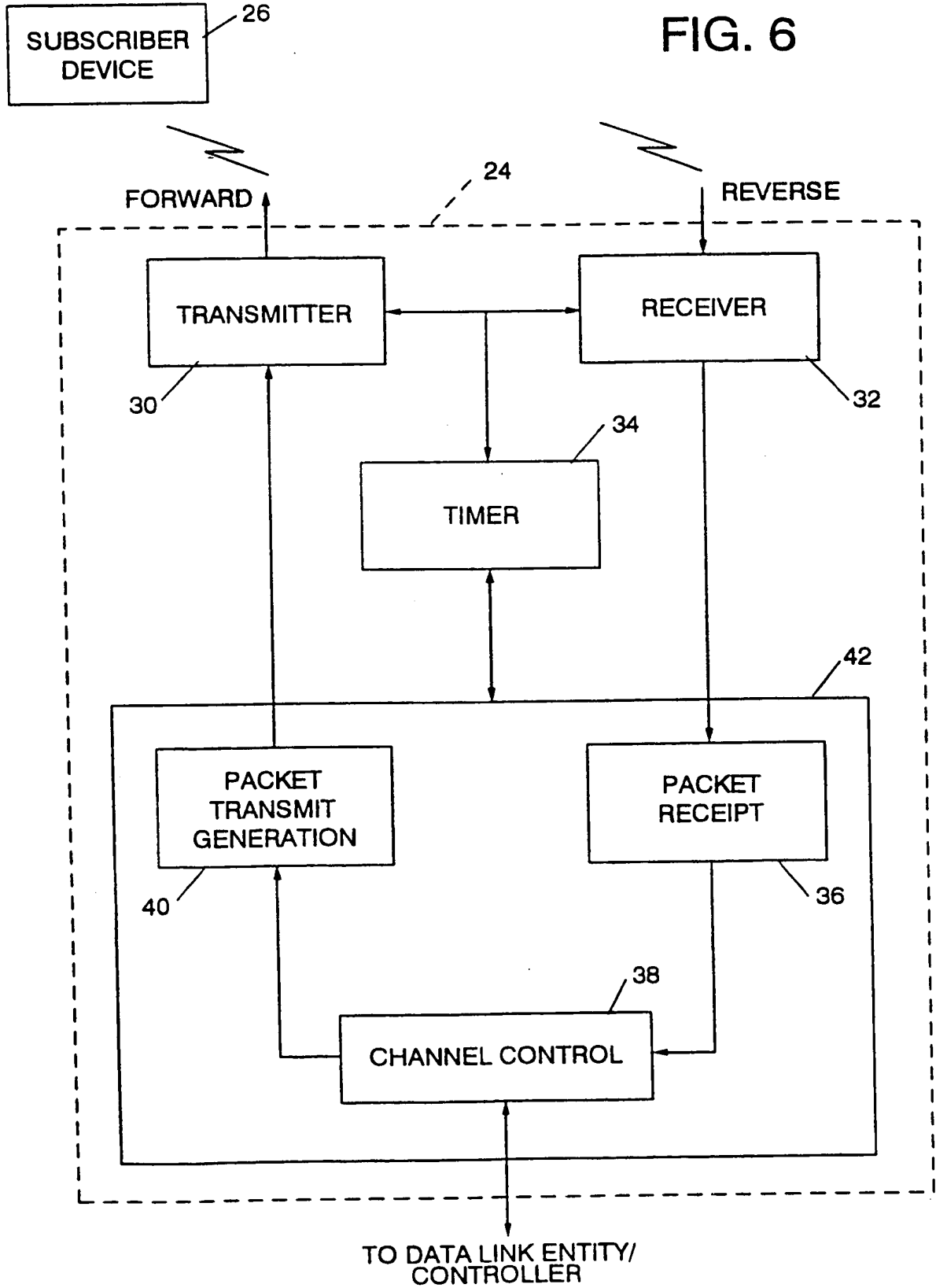

FIG. 7

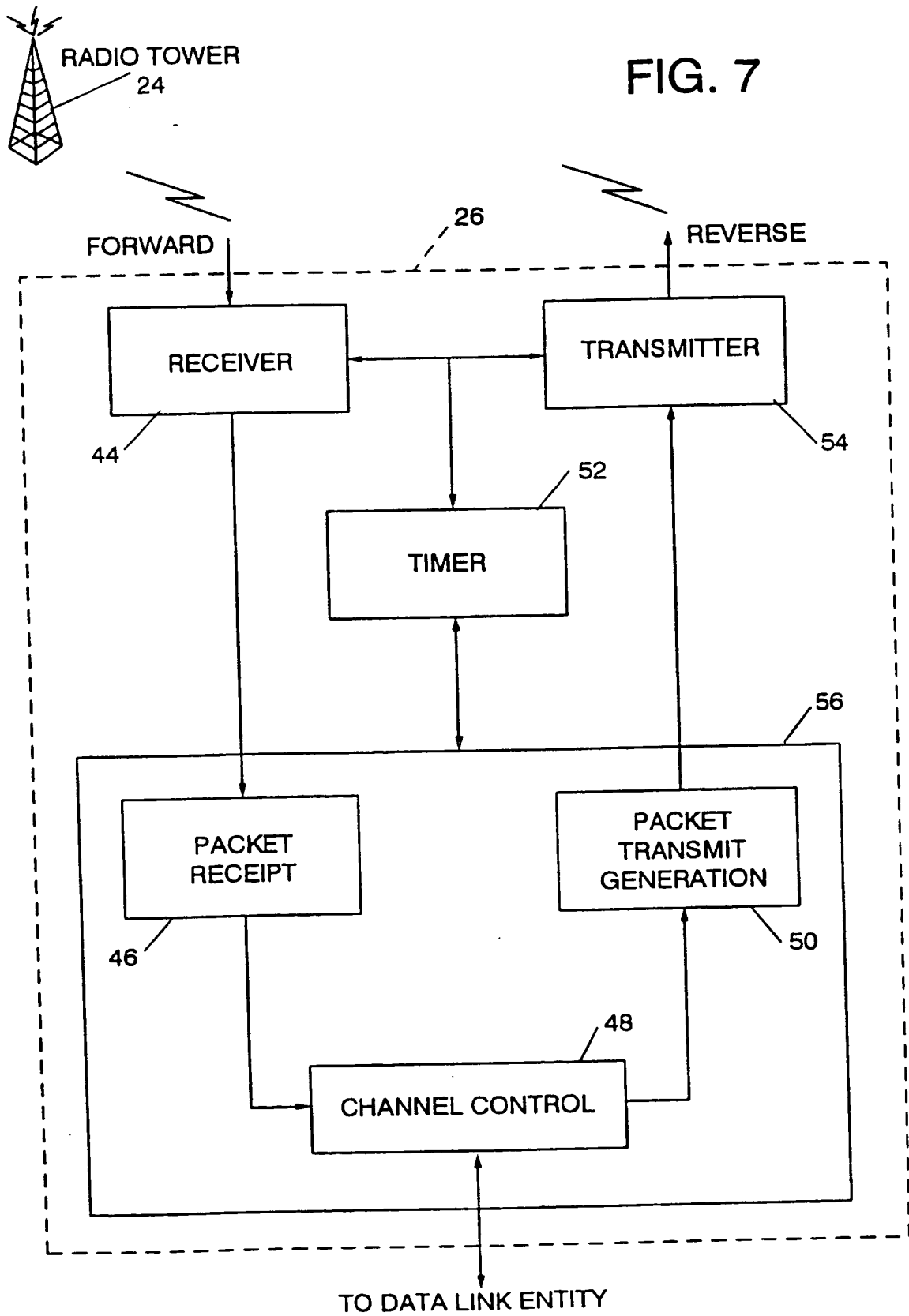

FIG. 8

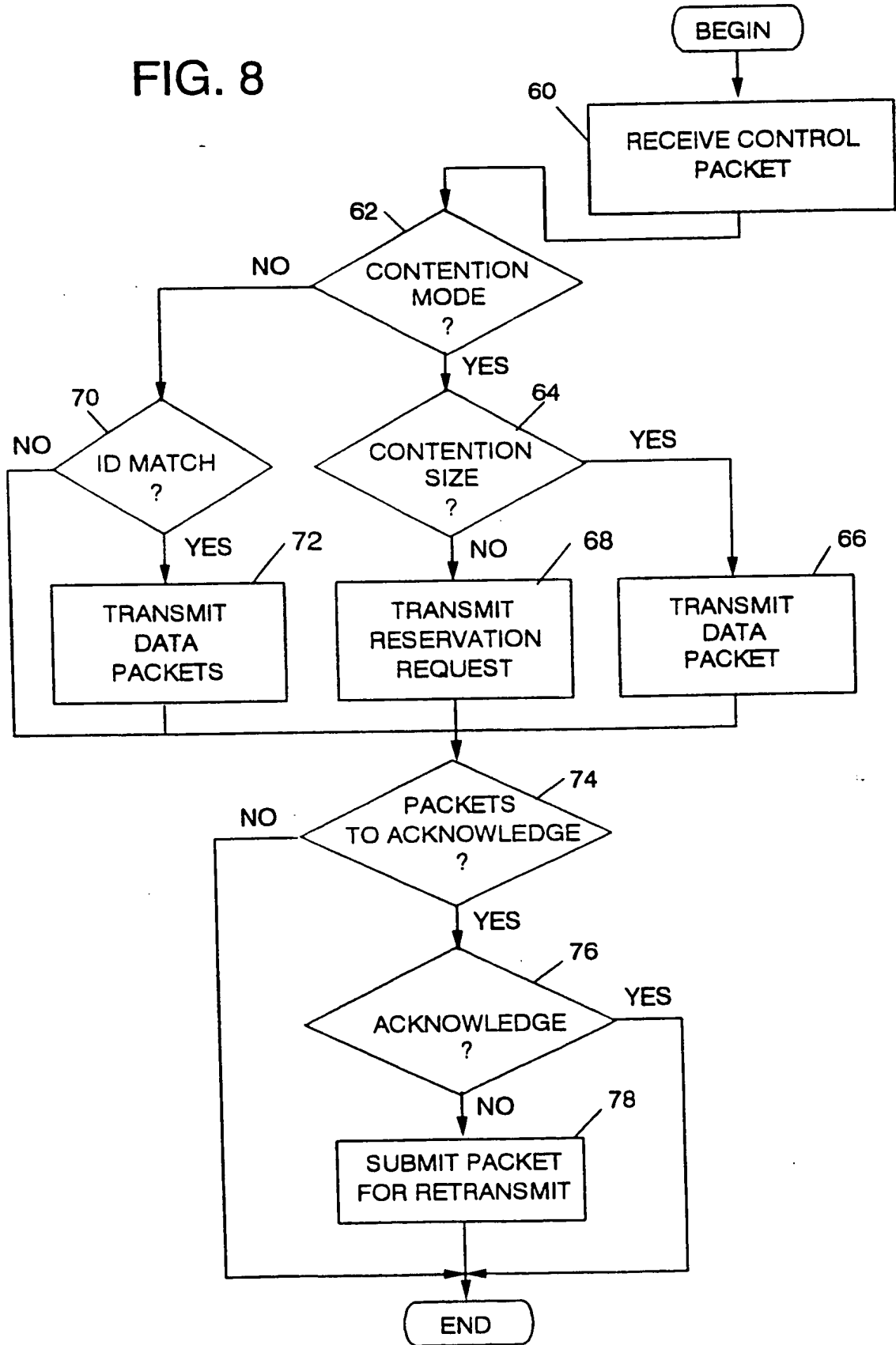

FIG. 9

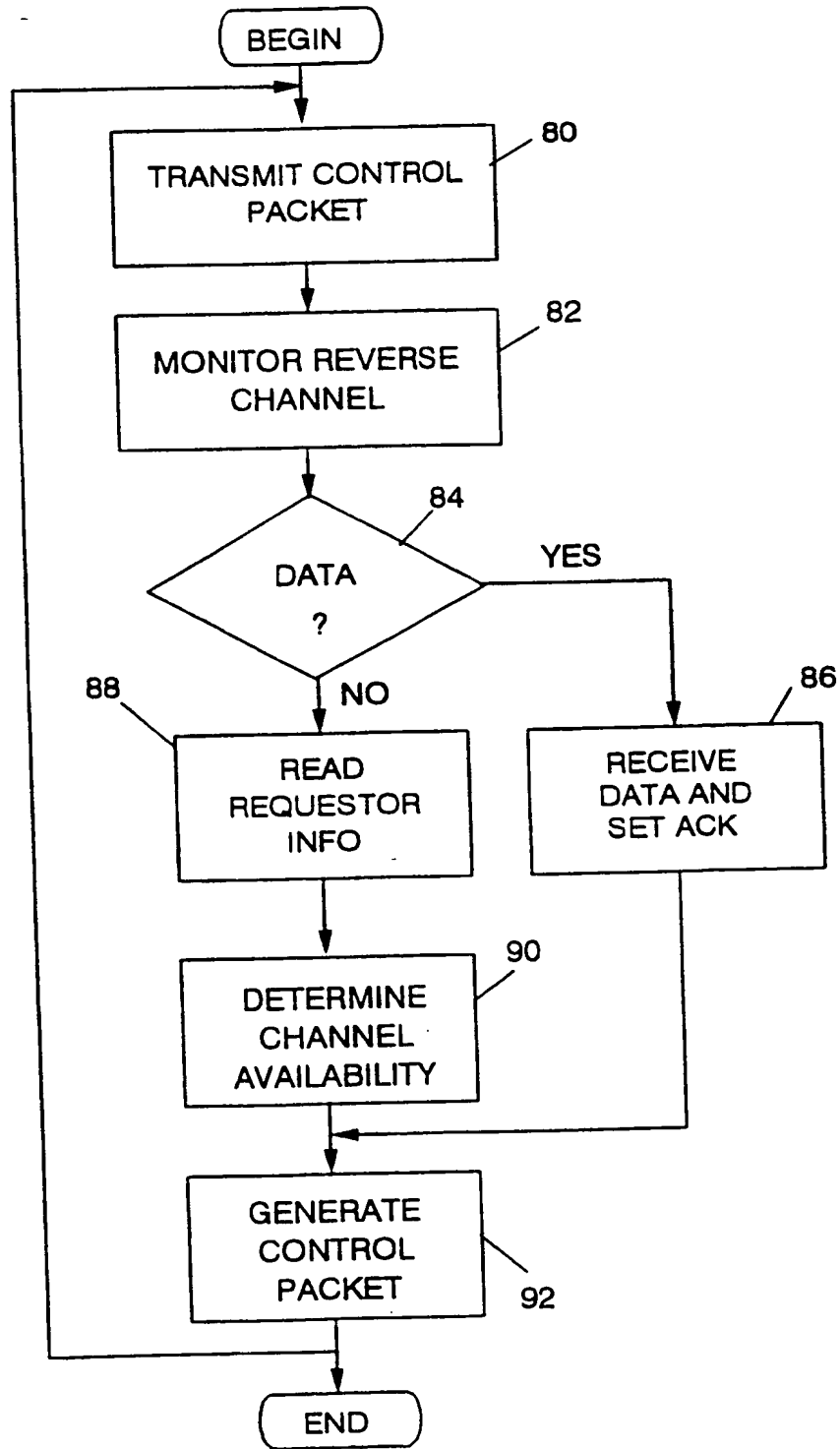
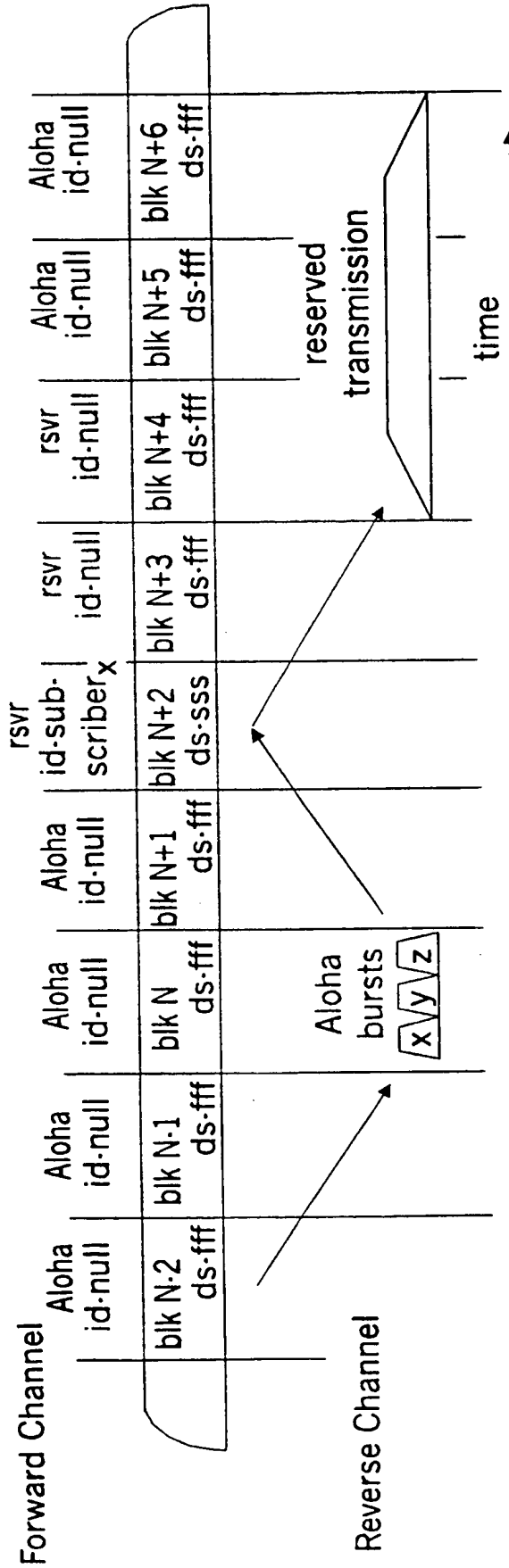

FIG. 10



rsvr/Aloha · Reservation/Aloha flag
 id-null · Reservation identifier
 ds-sss · decode status flags (f=fail, s=success)

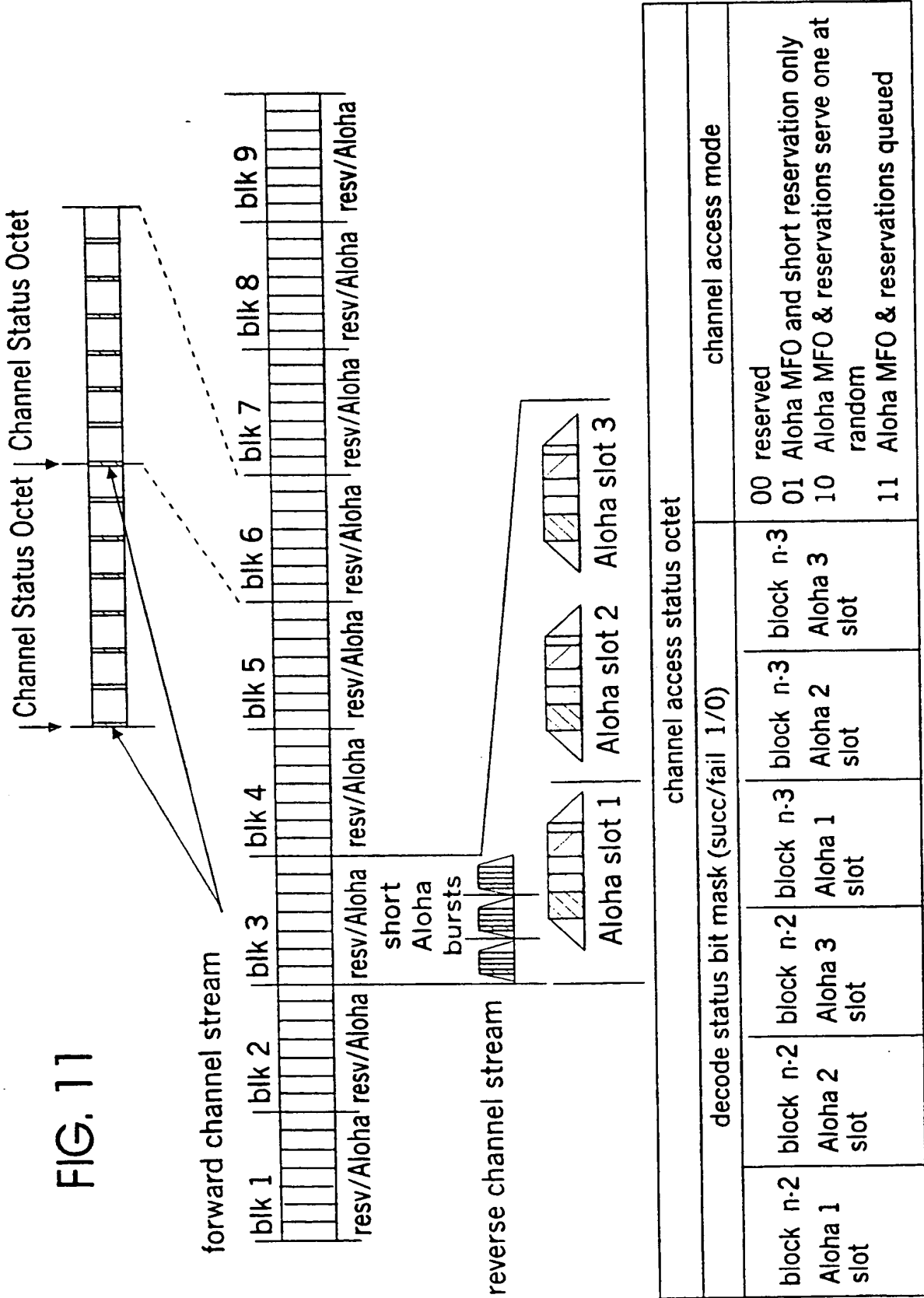
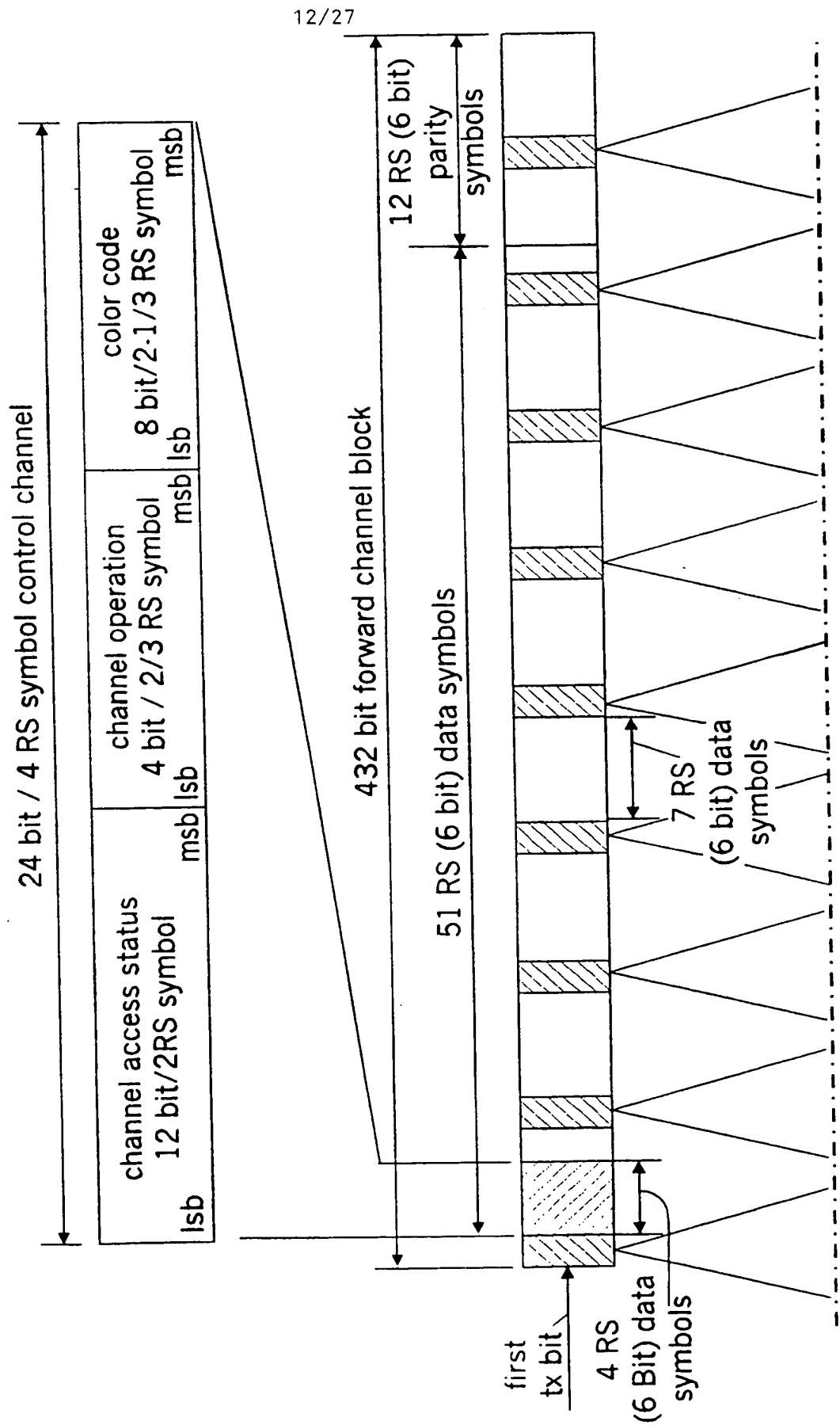

FIG. 12A



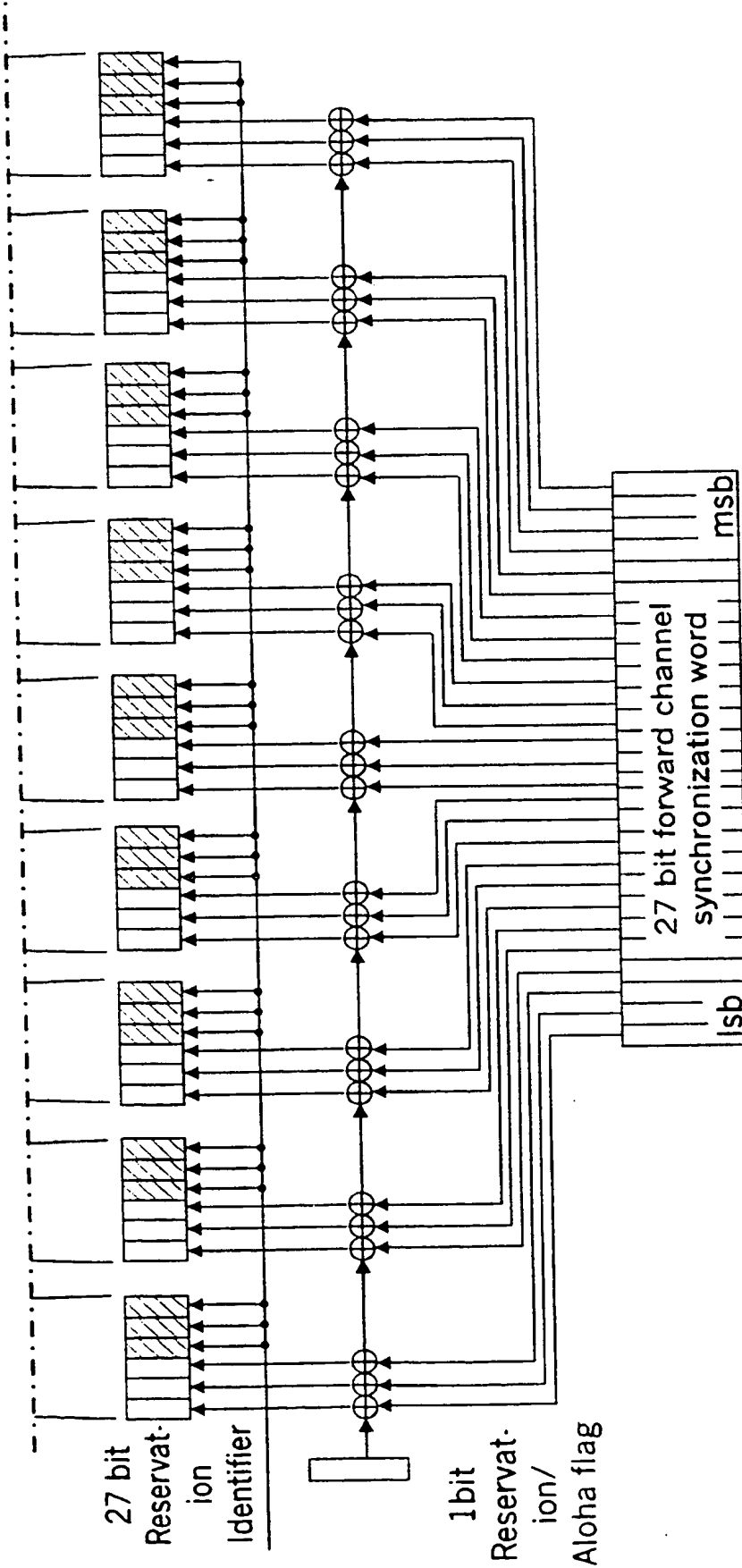
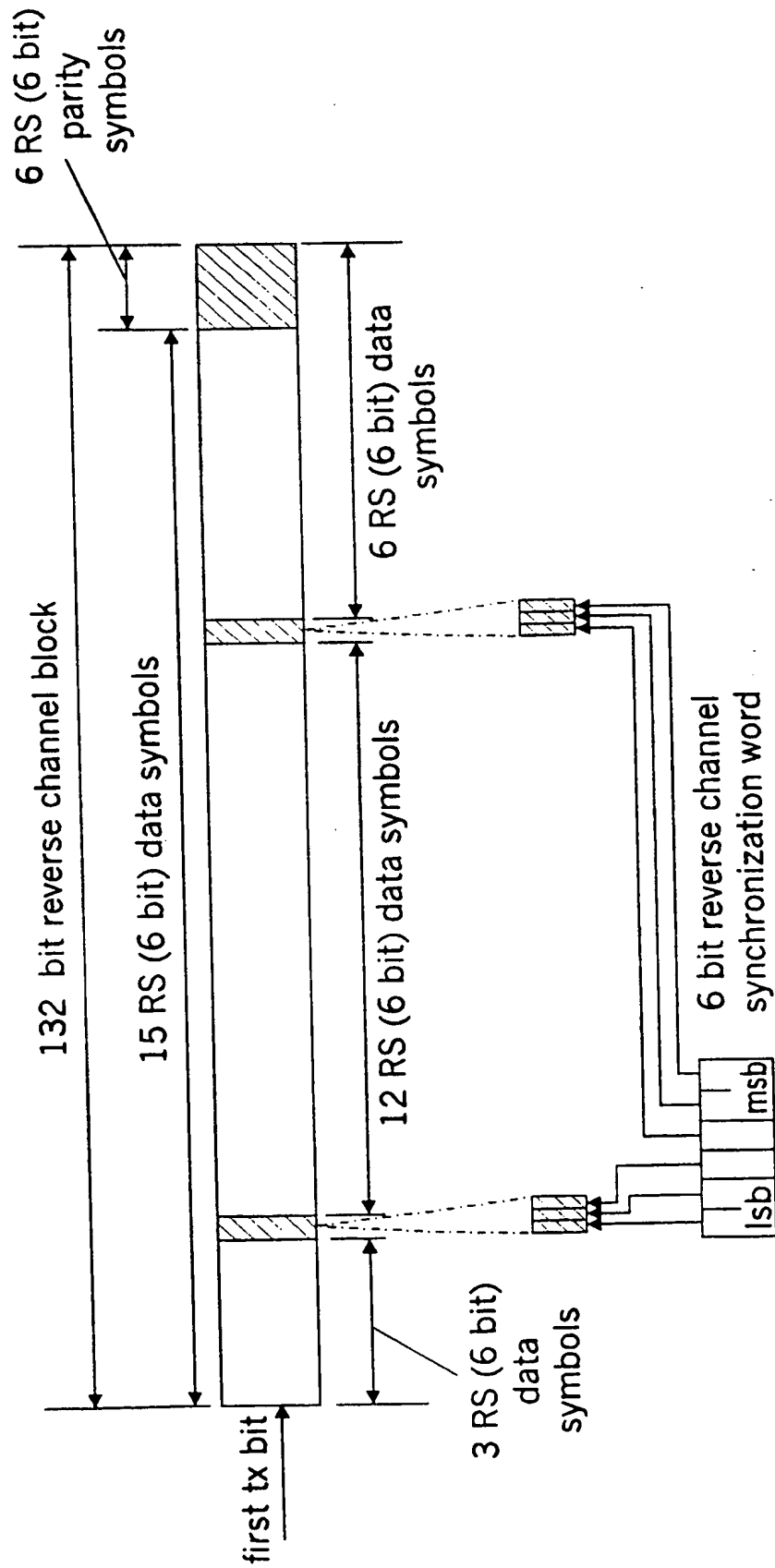

FIG. 12B

FIG. 12

FIG. 12A
FIG. 12B

FIG. 13



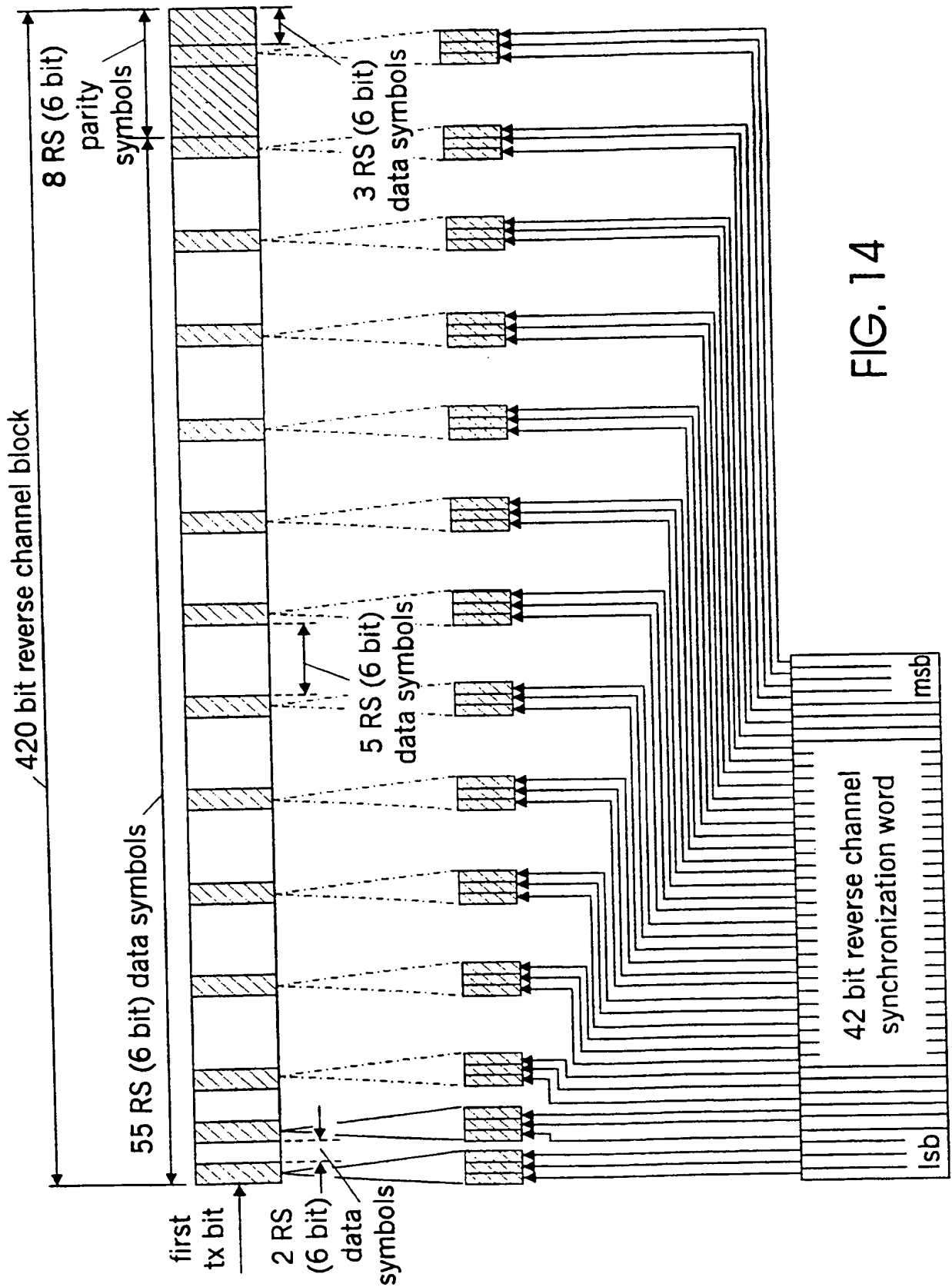

FIG. 14

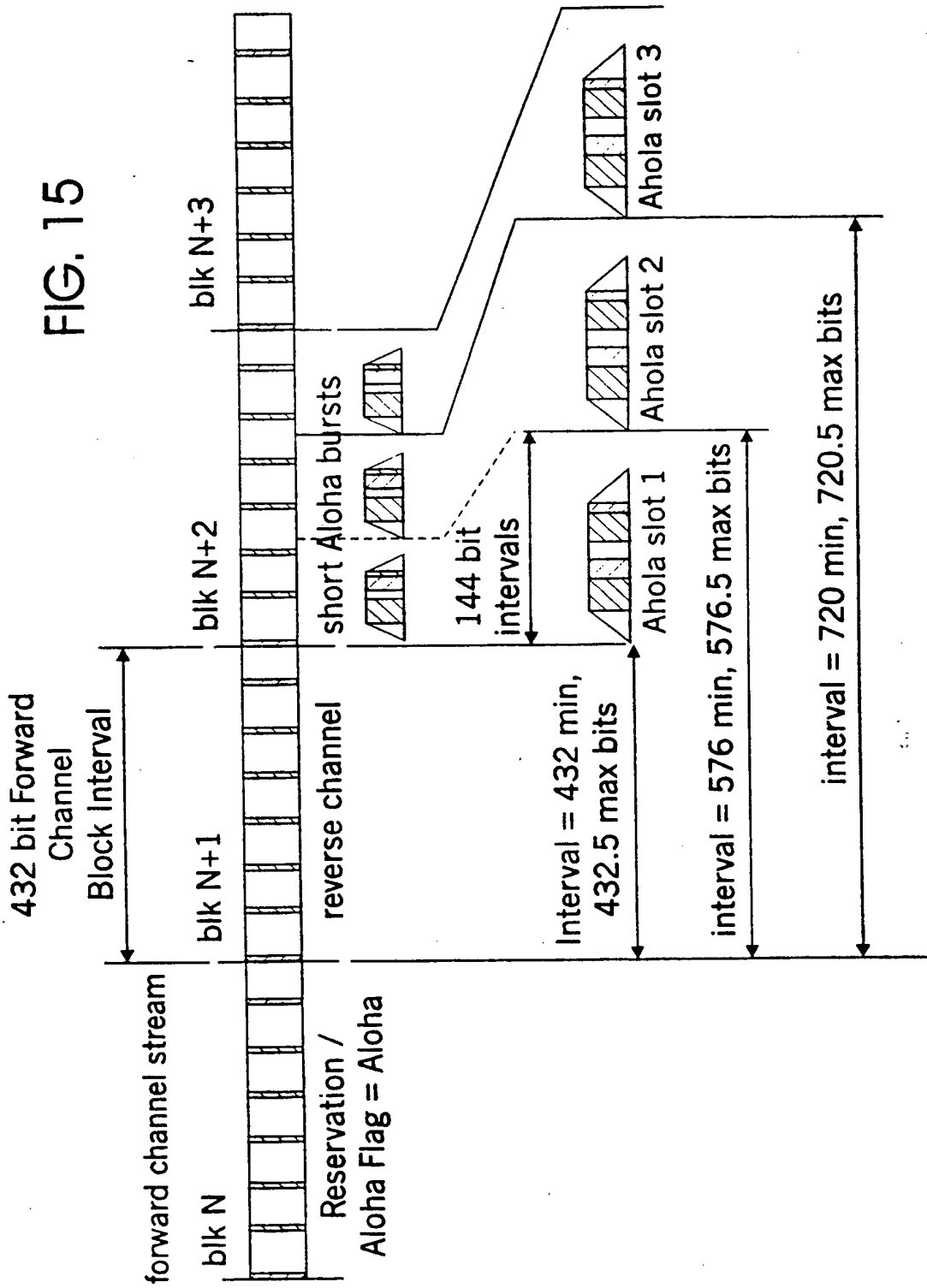

FIG. 16

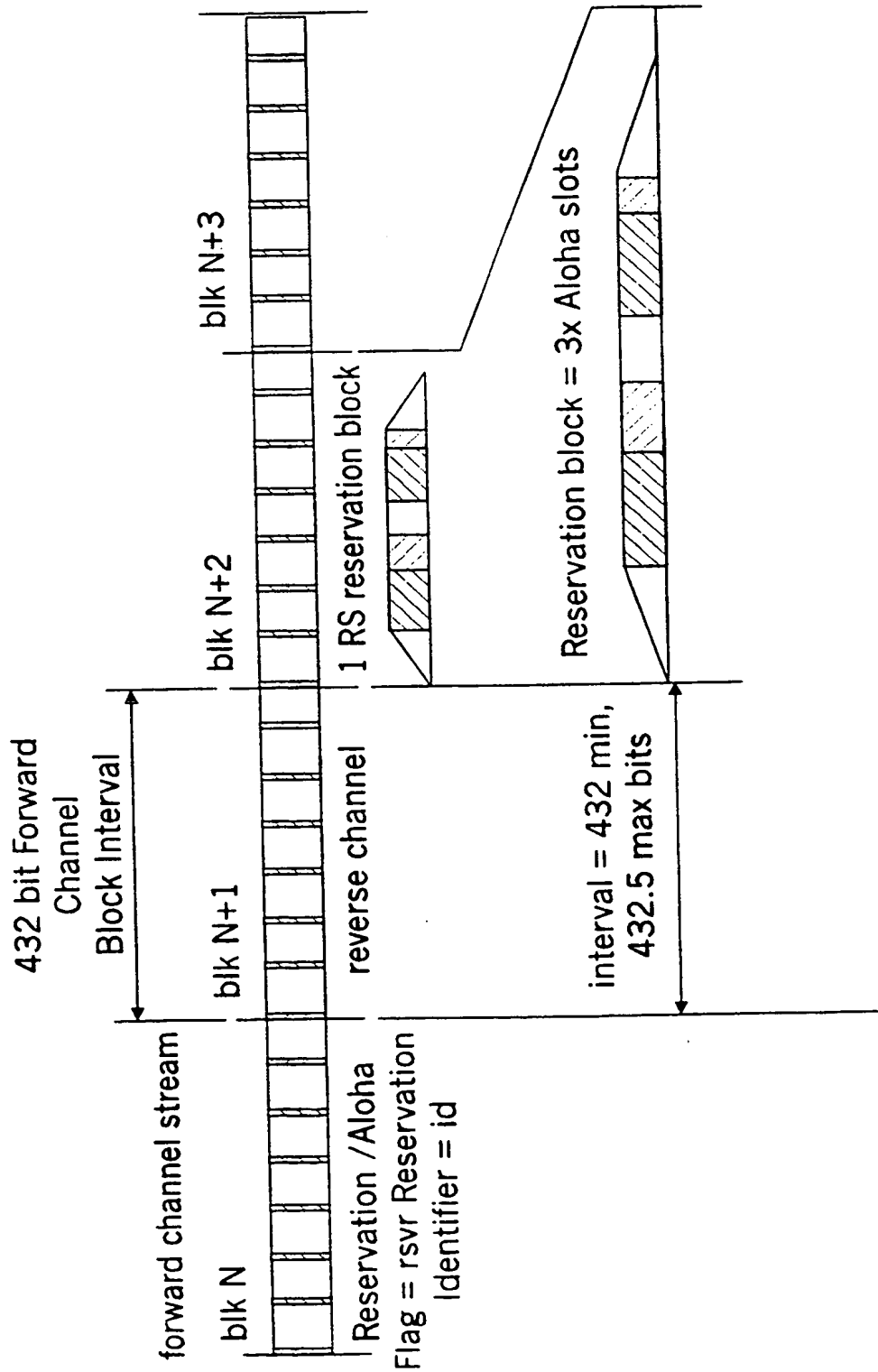
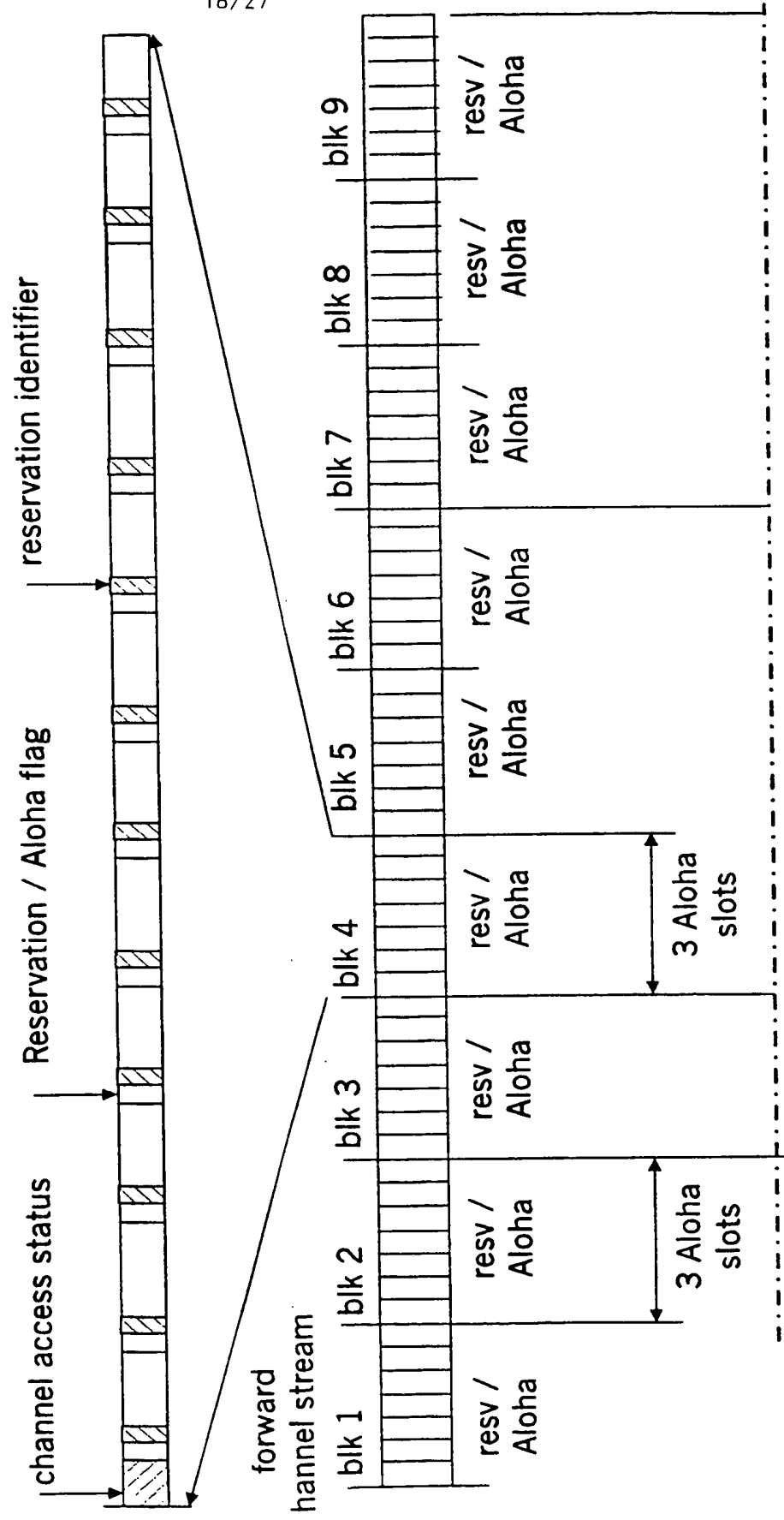

FIG. 17A
FIG. 17B

FIG. 17

FIG. 17A



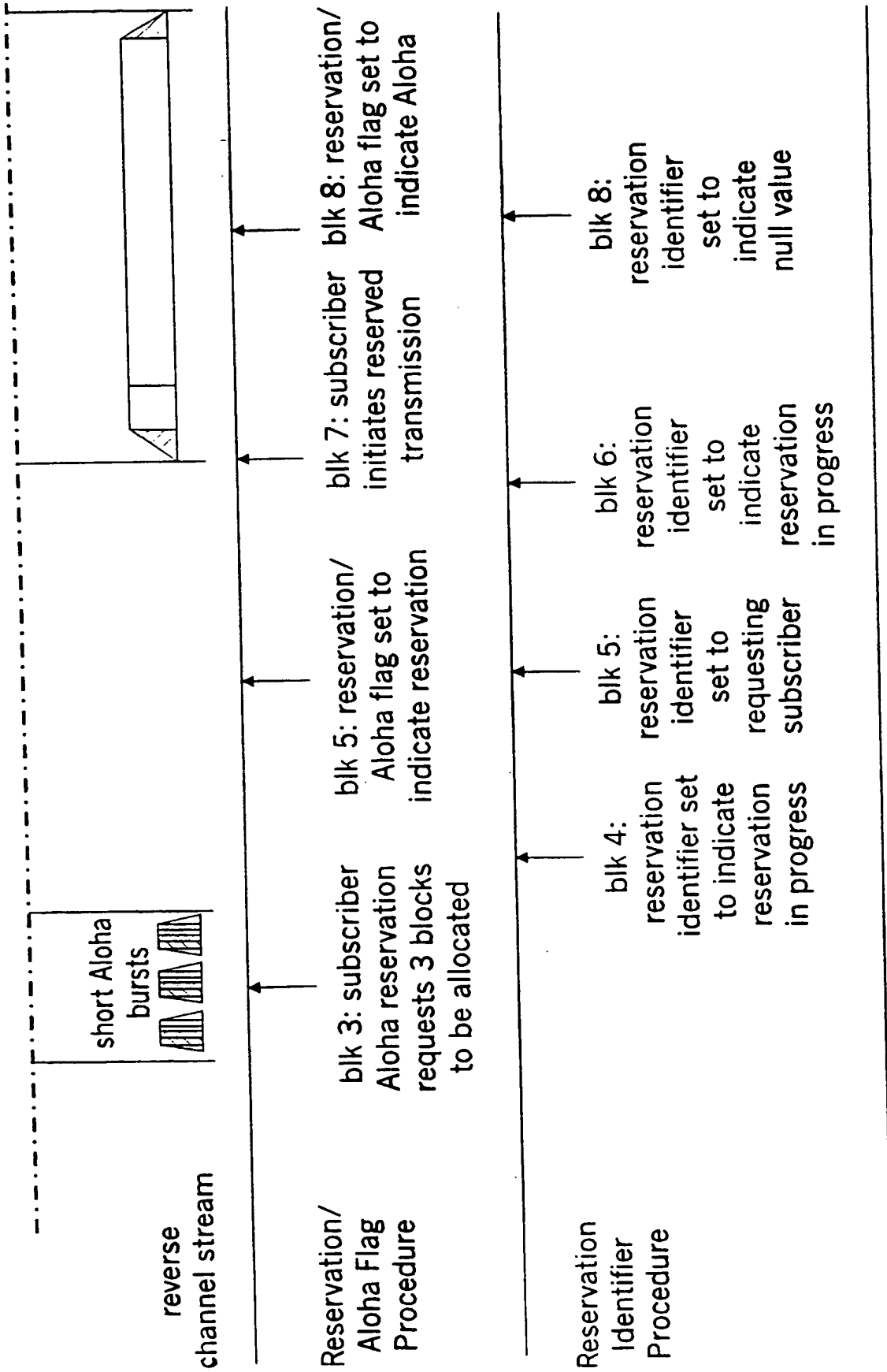

FIG. 17B

FIG. 18

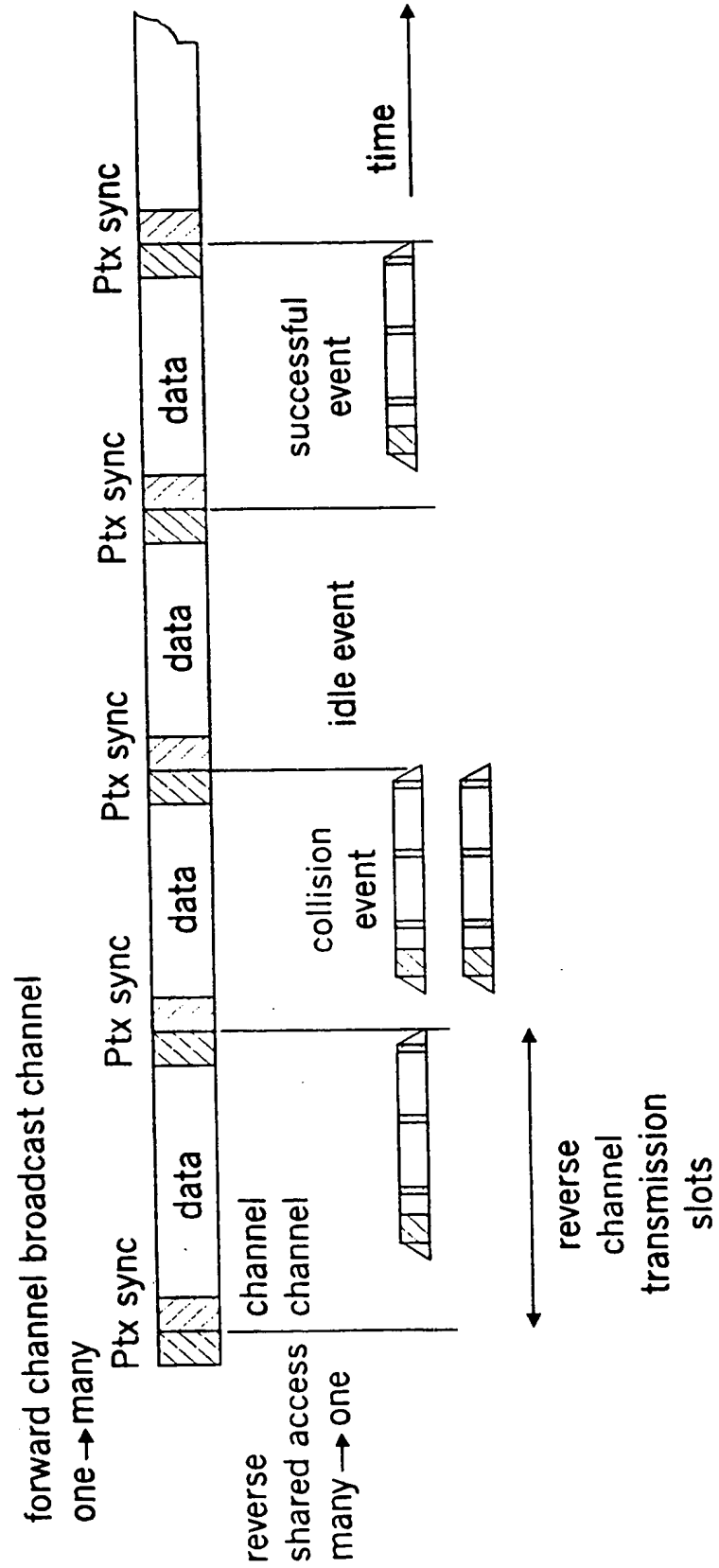

FIG. 19

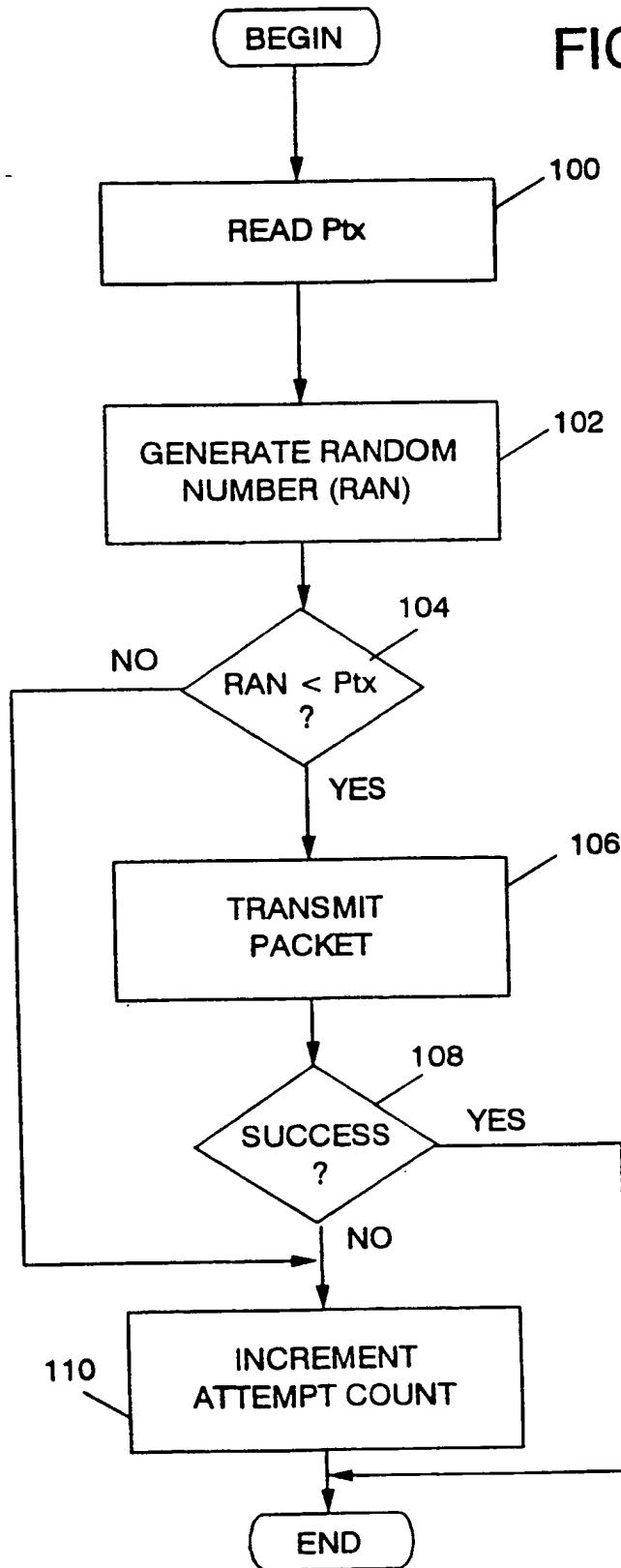

FIG. 20

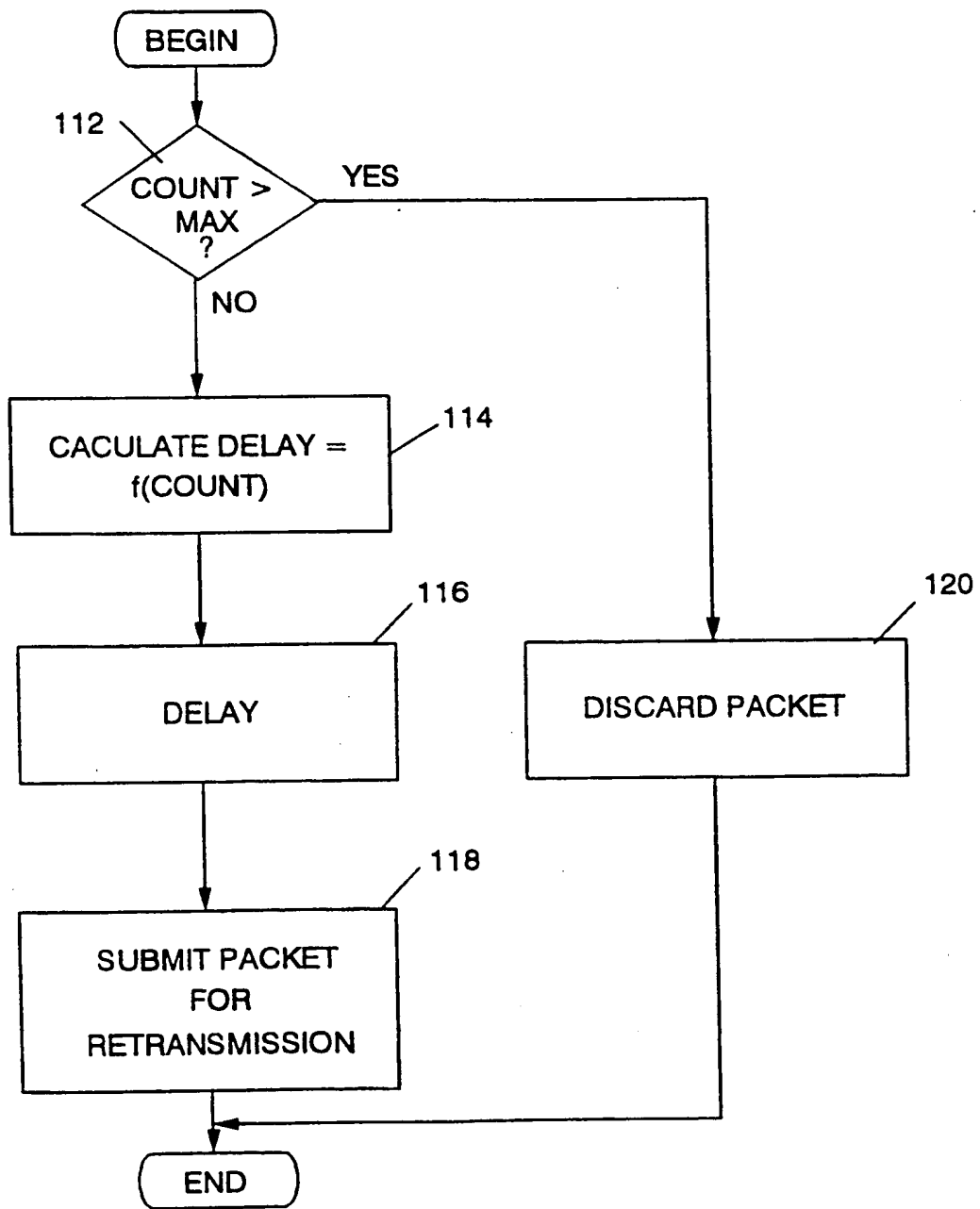

FIG. 21

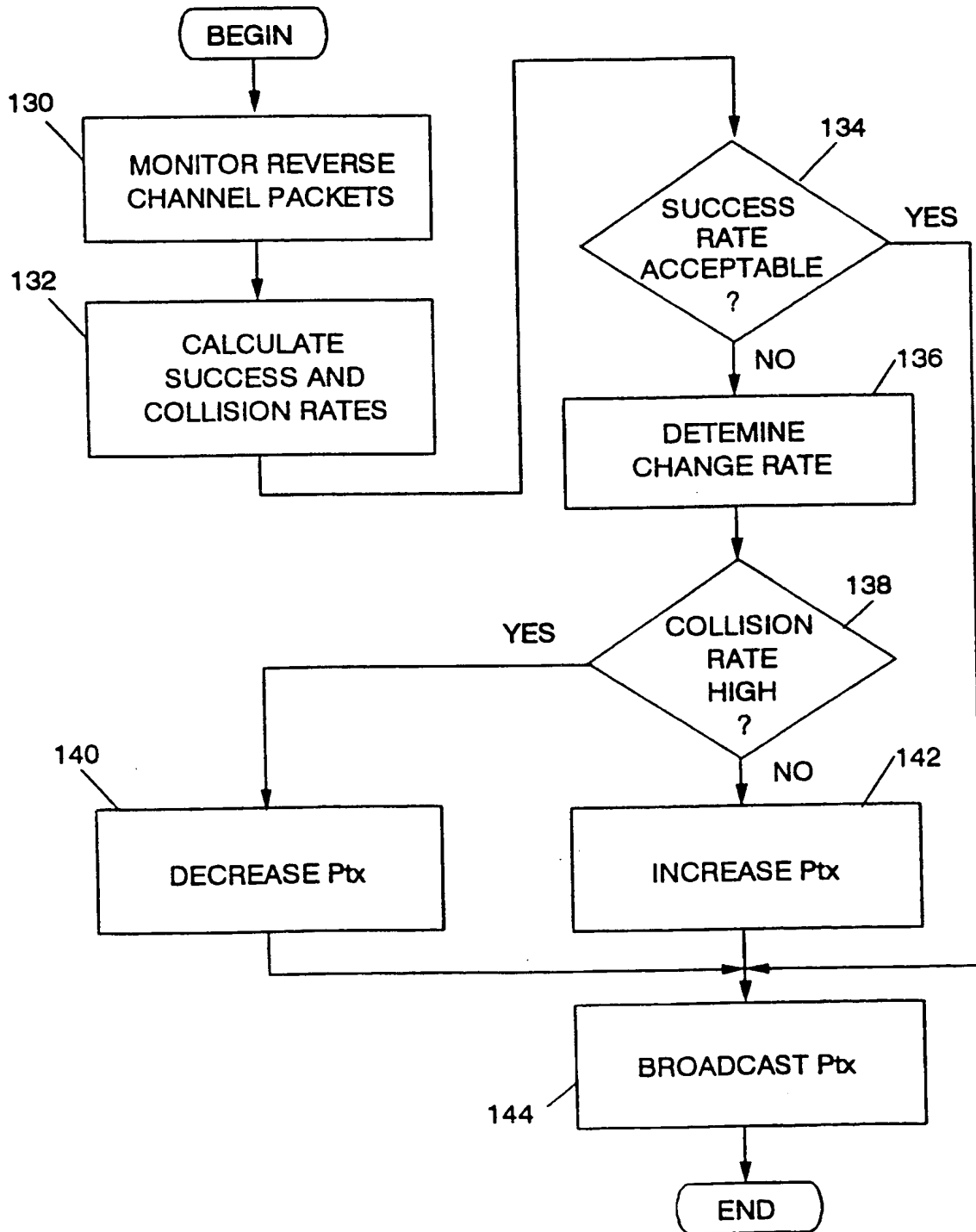

FIG. 22

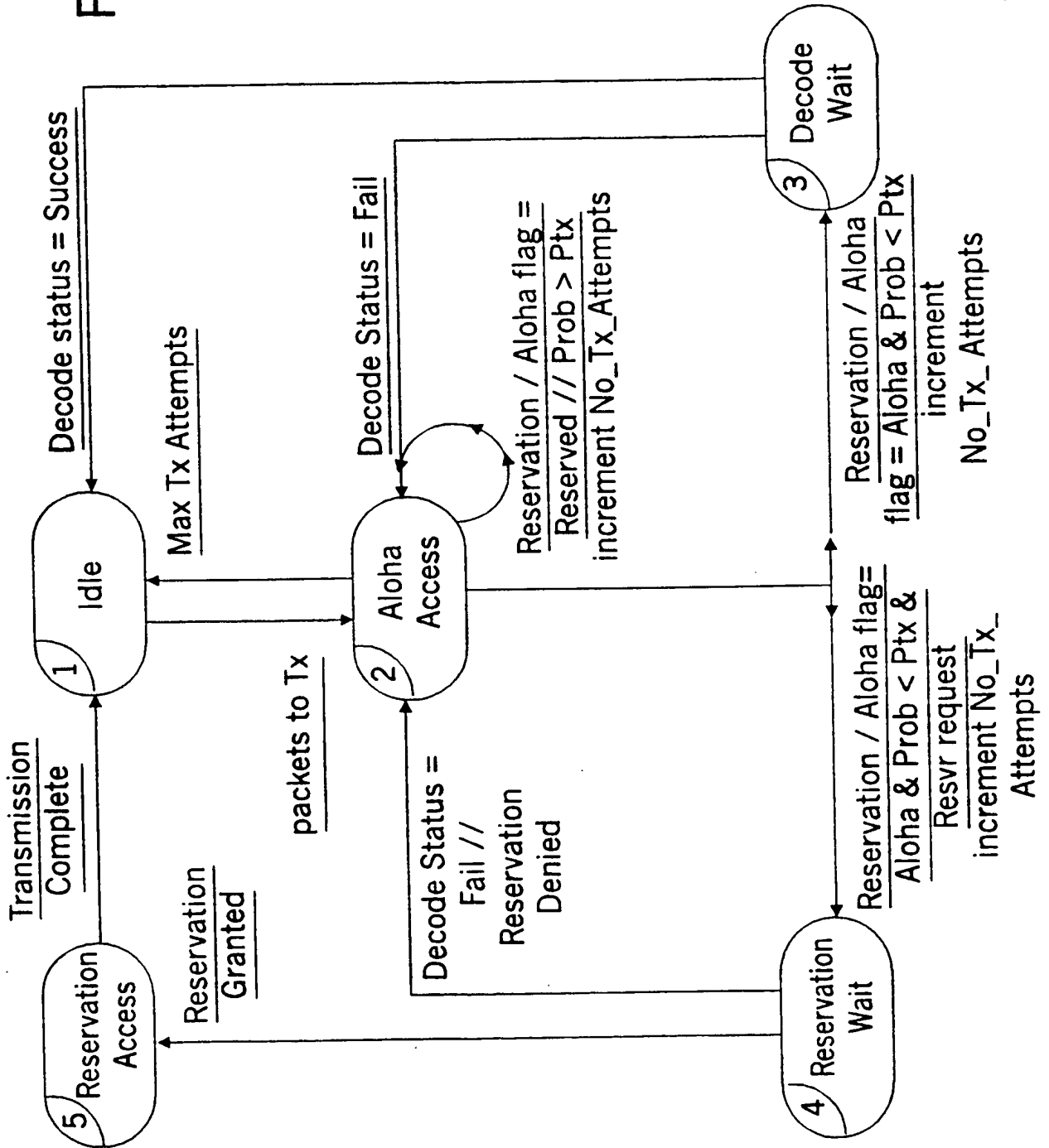

FIG. 23

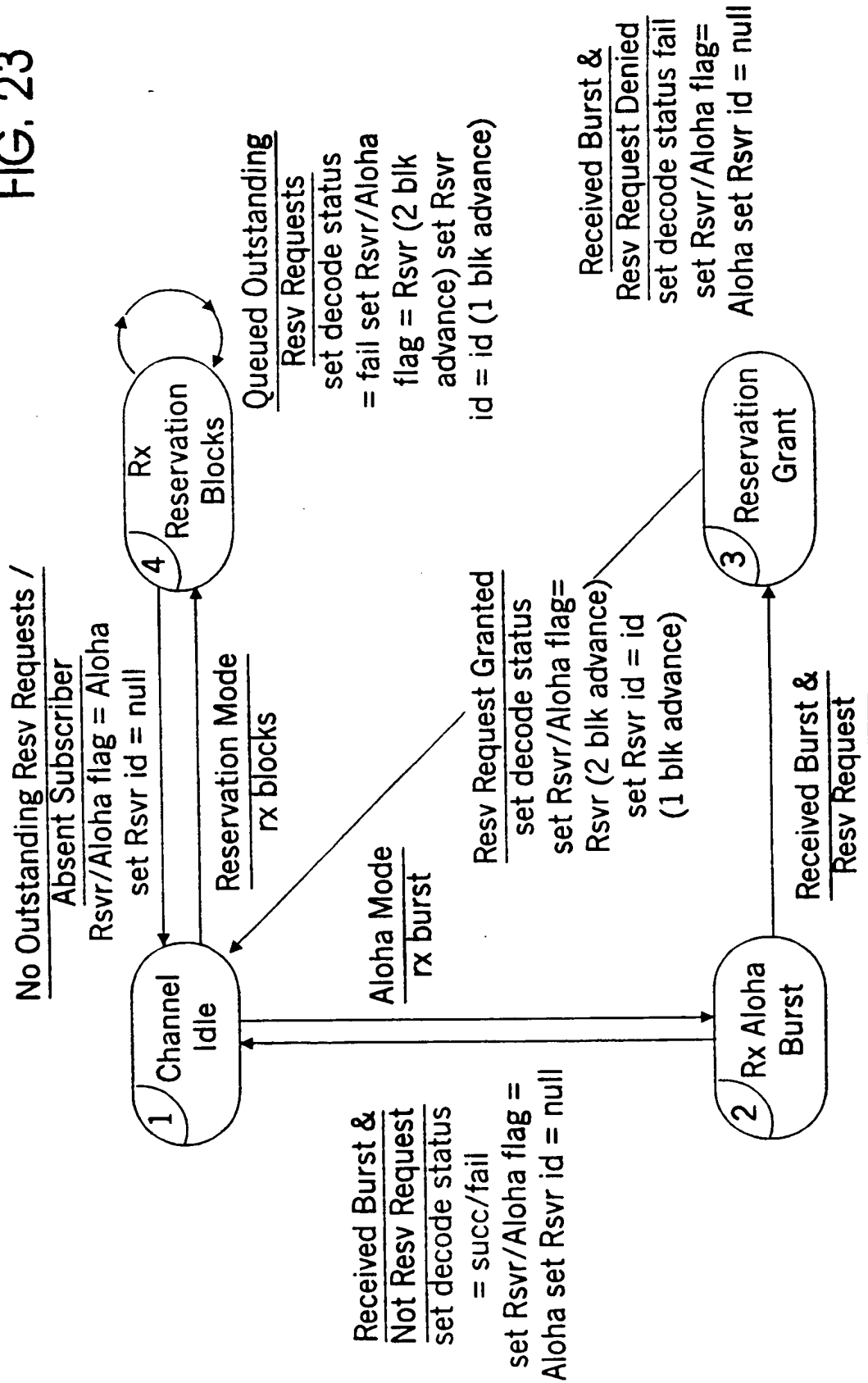

FIG. 24

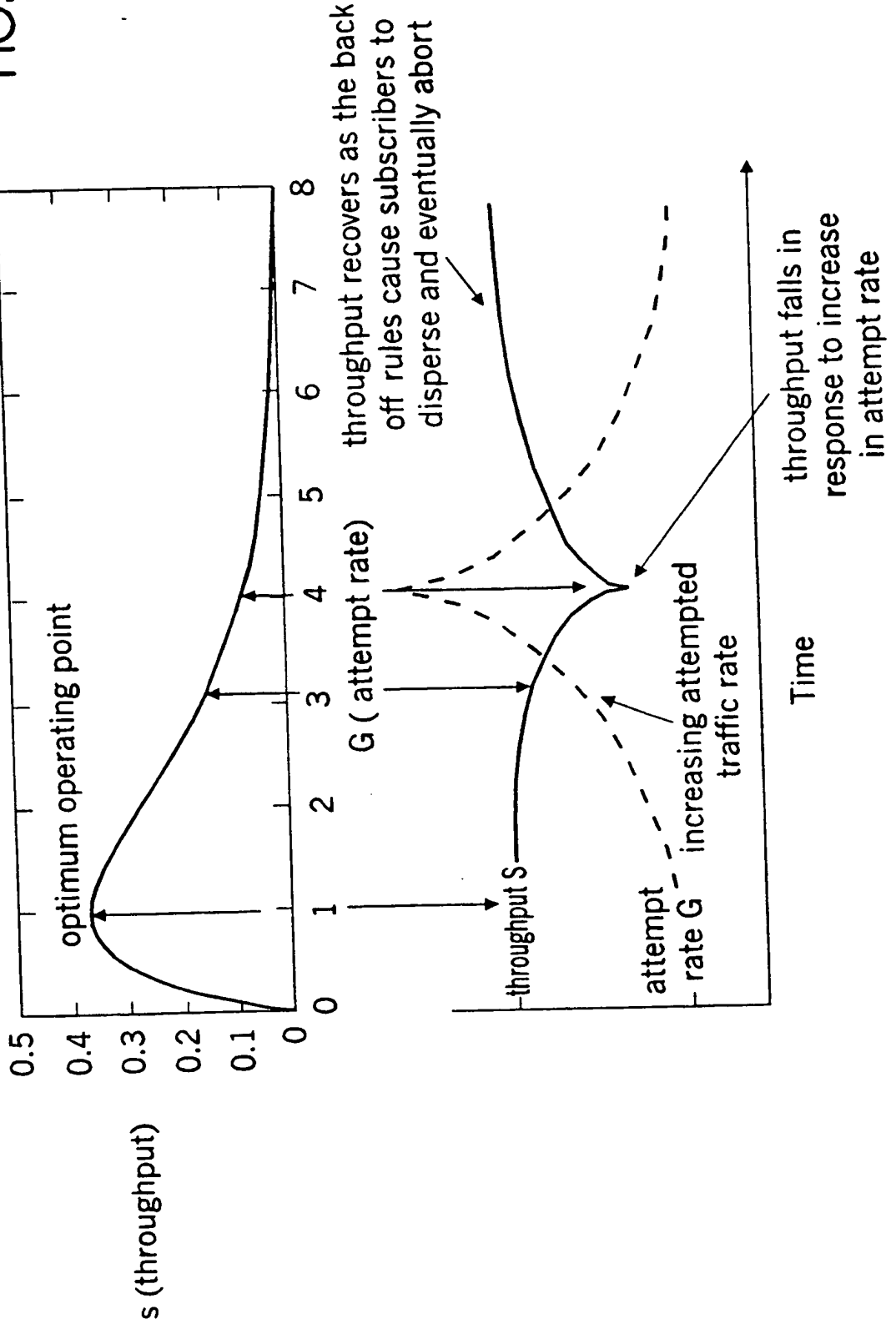
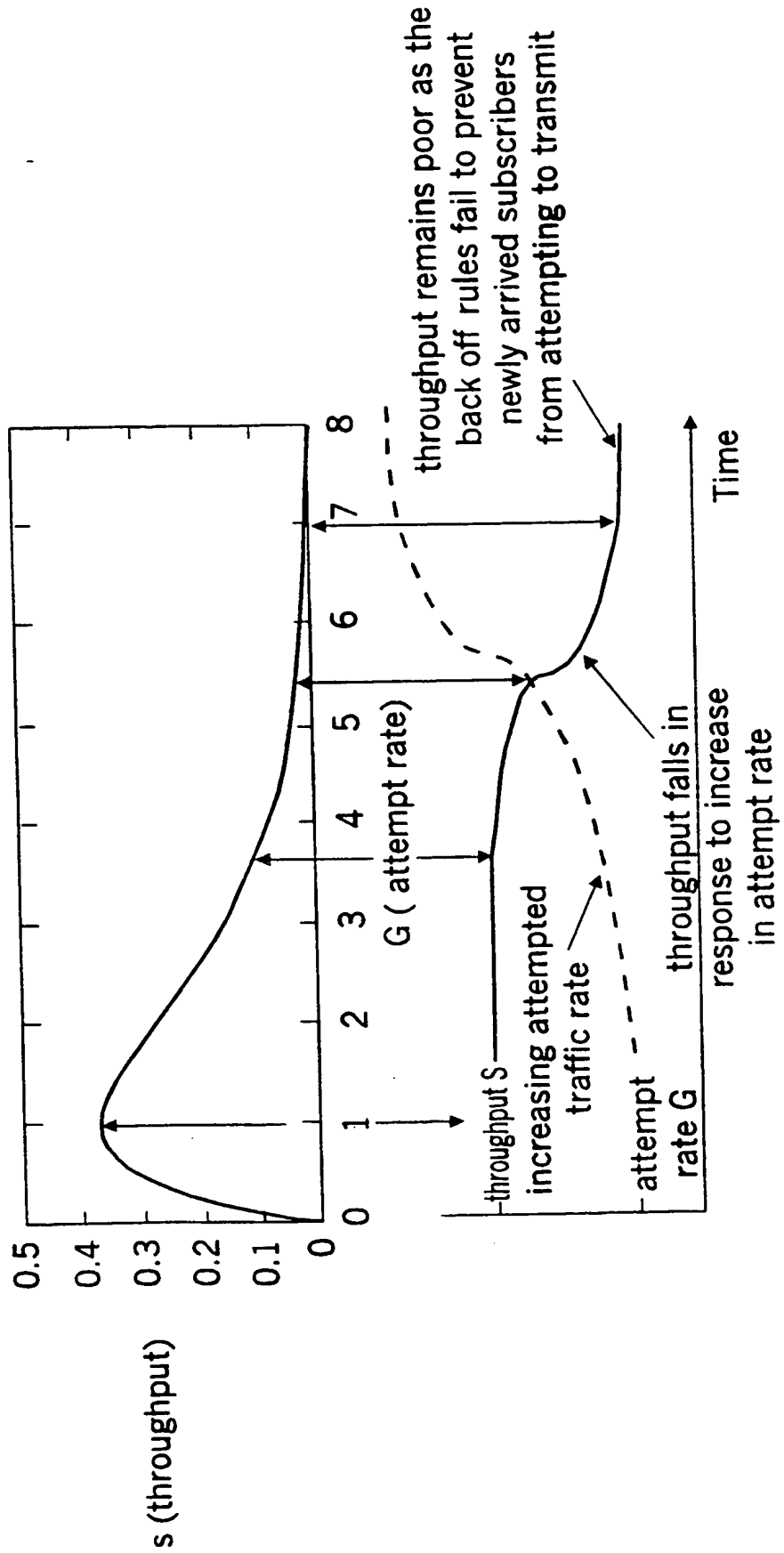

FIG. 25



INTERNATIONAL SEARCH REPORT

Inte. onal Application No

PCT/SE 98/00326

A. CLASSIFICATION OF SUBJECT MATTER

IPC 6 H04L12/56

According to International Patent Classification (IPC) or to both national classification and IPC

B. FIELDS SEARCHED

Minimum documentation searched (classification system followed by classification symbols)

IPC 6 H04L H04Q -

Documentation searched other than minimum documentation to the extent that such documents are included in the fields searched

Electronic data base consulted during the international search (name of data base and, where practical, search terms used)

C. DOCUMENTS CONSIDERED TO BE RELEVANT

Category	Citation of document, with indication, where appropriate, of the relevant passages	Relevant to claim No.
Y	US 5 295 140 A (CRISLER KENNETH J ET AL) 15 March 1994	1, 2, 5-8, 15, 16, 19, 20, 24-26, 29, 30
A	see abstract see column 1, line 7 - column 6, line 61	3, 17, 21-23, 27, 28
	--- -/--	

Further documents are listed in the continuation of box C

Patent family members are listed in annex.

Special categories of cited documents :

- "A" document defining the general state of the art which is not considered to be of particular relevance
- "E" earlier document but published on or after the international filing date
- "L" document which may throw doubts on priority claim(s) or which is cited to establish the publication date of another citation or other special reason (as specified)
- "O" document referring to an oral disclosure, use, exhibition or other means
- "P" document published prior to the international filing date but later than the priority date claimed

- "T" later document published after the international filing date or priority date and not in conflict with the application but cited to understand the principle or theory underlying the invention
- "X" document of particular relevance; the claimed invention cannot be considered novel or cannot be considered to involve an inventive step when the document is taken alone
- "Y" document of particular relevance; the claimed invention cannot be considered to involve an inventive step when the document is combined with one or more other such documents, such combination being obvious to a person skilled in the art.
- "&" document member of the same patent family

Date of the actual completion of the international search

24 June 1998

Date of mailing of the international search report

09/07/1998

Name and mailing address of the ISA

European Patent Office, P. B. 5818 Patentlaan 2
NL - 2280 HV Rijswijk
Tel. (+31-70) 340-2040, Tx. 31 651 epo nl.
Fax: (+31-70) 340-3016

Authorized officer

Vaskimo, K

INTERNATIONAL SEARCH REPORT

Inte. .onal Application No

PCT/SE 98/00326

C.(Continuation) DOCUMENTS CONSIDERED TO BE RELEVANT		
Category	Citation or document, with indication, where appropriate, of the relevant passages	Relevant to claim No.
Y	LEUNG V C M: "MULTICHANNEL RESERVATION PROTOCOLS FOR SATELLITE MULTIPLE ACCESS NETWORKS" PROCEEDINGS OF THE PACIFIC RIM CONFERENCE ON COMMUNICATIONS, COMPUT AND SIGNAL PROCESSING, VICTORIA, CA, MAY 9 - 10, 1991, vol. VOL. 2, no. -, 9 May 1991, INSTITUTE OF ELECTRICAL AND ELECTRONICS ENGINEERS, pages 414-417, XP000280332 see abstract see paragraph I - paragraph III	1,2,5-8, 15,16. 19,26. 29,30
A	---	3,9,10, 17,20, 27,28
Y	RAYCHAUDHURI D: "SELECTIVE REJECT ALOHA/HCFs WITH IMPLICIT RESERVATION" WORLD PROSPERITY THROUGH COMMUNICATIONS. BOSTON, JUNE 11 - 14, 1989, vol. VOL. 1, no. -, 11 June 1989, INSTITUTE OF ELECTRICAL AND ELECTRONICS ENGINEERS, pages 487-493, XP000075496 see abstract see paragraph I - paragraph III	1,2,15, 16,19, 26,29,30
A	---	3,5,17, 20,27,28
Y	WO 96 22000 A (ERICSSON TELEFON AB L M ;JONSSON BJOERN ERIK RUTGER (SE)) 18 July 1996 see abstract see page 1, line 4 - page 3, line 22 see page 6, line 21 - page 11, line 18 see page 15, line 9 - page 16, line 37 see page 20, line 18 - line 39 see page 27, line 27 - page 28, line 3	20,24,25
A	---	1,16, 21-23, 26,30
P,Y	EP 0 765 096 A (NIPPON TELEGRAPH & TELEPHONE) 26 March 1997 see abstract see column 2, line 21 - line 39 see column 3, line 44 - column 4, line 10 see column 6, line 6 - line 17 see column 7, line 53 - column 11, line 16 see column 12, line 3 - line 54 see column 18, line 52 - column 20, line 3 see column 21, line 25 - line 50	1,2,15, 16,19, 26,29,30
A	---	3,5,17, 20,27,28
2	---	-/--

INTERNATIONAL SEARCH REPORT

International Application No

PCT/SE 98/00326

C.(Continuation) DOCUMENTS CONSIDERED TO BE RELEVANT

Category	Citation of document, with indication, where appropriate, of the relevant passages	Relevant to claim No.
A	<p>MICHEL MOULY, MARIE-BERNADETTE PAUTET: "The GSM System for Mobile Communications" 2 September 1993, EUROPE MEDIA, LASSAY-LES-CHATEAUX, FR. XP002069141 200240 see page 192, paragraph 4.1.3.1. see page 424, paragraph 6.3.10. - page 429, paragraph 6.3.10.6 -----</p>	1-30

INTERNATIONAL SEARCH REPORT

Information on patent family members

International Application No

PCT/SE 98/00326

Patent document cited in search report		Publication date		Patent family member(s)	Publication date
US 5295140	A	15-03-1994		EP 0577747 A	12-01-1994
				HU 65532 A	28-06-1994
				JP 6506579 T	21-07-1994
				WO 9217957 A	15-10-1992

WO 9622000	A	18-07-1996		AU 4461196 A	31-07-1996
				CA 2197859 A	18-07-1996
				EP 0803168 A	29-10-1997
				FI 971514 A	11-04-1997
				NO 973140 A	28-08-1997
				SE 9500066 A	11-07-1996

EP 0765096	A	26-03-1997		JP 9093646 A	04-04-1997
				JP 9233051 A	05-09-1997
